



LUBRICATION SYSTEM

CHECK & CHANGE OF ENGINE OIL	LU- 2
OIL QUALITY & LEVEL CHECK	LU- 2
CHANGE OF ENGINE OIL & REPLACEMENT OF OIL FILTER	LU- 2
OIL PRESSURE WARNING LAMP	LU- 4
OIL PRESSURE CHECK	LU- 4
OIL PUMP	LU- 6
COMPONENTS	LU- 6
REMOVAL	LU- 7
INSPECTION	LU- 8
INSTALLATION	LU- 9
SERVICE SPECIFICATIONS	LU-11
SSTs	LU-11
TIGHTENING TORQUE	LU-11

JLU00001-00000

LU-2

CHECK & CHANGE OF ENGINE OIL OIL QUALITY & LEVEL CHECK

WARNING:

- Be sure to perform this inspection when the engine oil is not hot, to prevent you from getting scalded.

1. Park the vehicle on a level surface.
2. Pull out the oil level gauge.
JLU00002-00000
3. Check the engine oil for deterioration, ingress of water, discoloring or dilution.
If oil quality is poor, change the engine oil.
(As for the procedure, see "CHANGE OF ENGINE OIL AND REPLACEMENT OF OIL FILTER" section.)
4. Wipe off the engine oil from the oil level gauge.
5. Reinsert the oil level gauge as far as it will go.
6. Pull out the oil level gauge again.
7. Ensure that the engine oil level is between the "L" level and "F" level on the oil level gauge.
If the engine oil level is below the "L" level, replenish the specified engine oil to the "F" level after the checking of the oil quality and leakage.
JLU00003-00000

CAUTION:

- Use API grade SH or higher multi-grade viscosity, fuel efficient oil. (As for the procedure, see "CHANGE OF ENGINE OIL AND REPLACEMENT OF OIL FILTER" section.)

NOTE:

- The amount of oil whose level is between "L" level and "F" level equals to 1.5 liter.

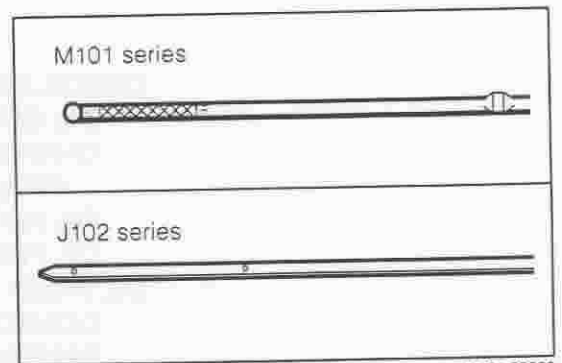

CHANGE OF ENGINE OIL & REPLACEMENT OF OIL FILTER

WARNING:

- Protect your eyes by wearing safety goggles.
- Be very careful not to burn yourself with hot engine oil or hot engine components.
JLU00005-00000

1. Drain engine oil
 - (1) Park the vehicle on a level surface.
 - (2) Place a suitable container under the oil drain plug.
 - (3) Remove the drain plug and gasket, and drain the engine oil into the placed container completely.
 - (4) Remove the oil filler cap.

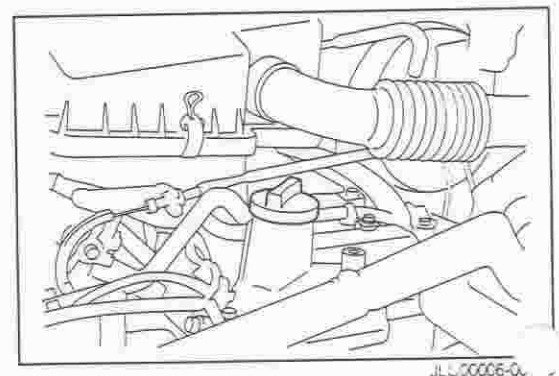

2. Replacement of oil filter

- (1) Place a suitable container under the oil filter.
- (2) Slacken the oil filter with a suitable oil filter wrench or the following SST.
SST: 09228-87201-000

CAUTION:

- Be careful at this time, for the oil may flow out.

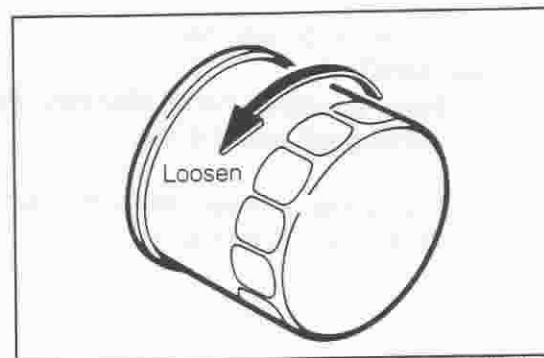

JLU00007-0006

- (3) Remove the oil filter by hand.
- (4) Wipe off the engine oil from the oil filter attaching part of the engine.
- (5) Thinly apply engine oil to the O-ring of the new oil filter.
- (6) Screw in the oil filter by hand, until the O-ring of the oil filter contacts the oil filter installing surface.

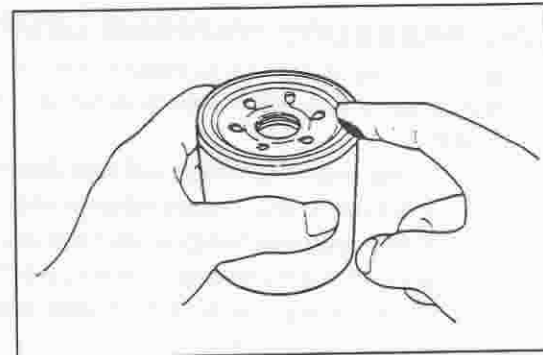

JLU00008-0007

- (7) Tighten the oil filter three fourths to one complete turn, using a suitable oil filter wrench or the following SST.
SST: 09228-87201-000

CAUTION:

- Do not overtighten the oil filter. Failure to observe this caution will cause oil leakage or damage of the oil pump or oil filter.

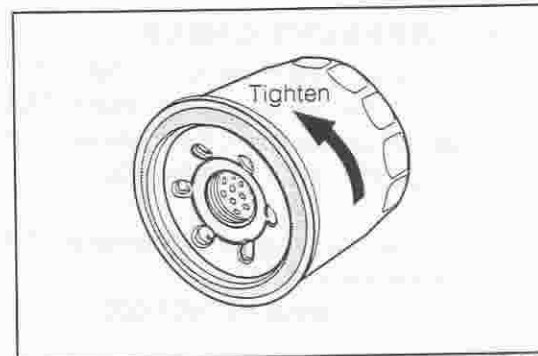

JLU00009-0008

3. Filling of engine oil

- (1) Clean the drain plug. Tighten the drain plug to the specified torque with a new gasket interposed.
Tightening Torque: 23.6 - 35.4 N·m

JLU00010-0000

- (2) Detach the filler cap. Pour oil into the engine through the filler cap port.

NOTE:

- Use multigrade viscosity, fuel-efficient engine oil of API grade SH or higher.

Oil capacity		Model	M101	J102
Whole			4.1 l	3.6 l
Oil pan (Low/Full)			2.0 l / 3.5 l	1.5 l / 3.0 l
Oil change	with oil filter replacement		3.6 l	3.2 l
	without oil filter replacement		3.3 l	3.0 l

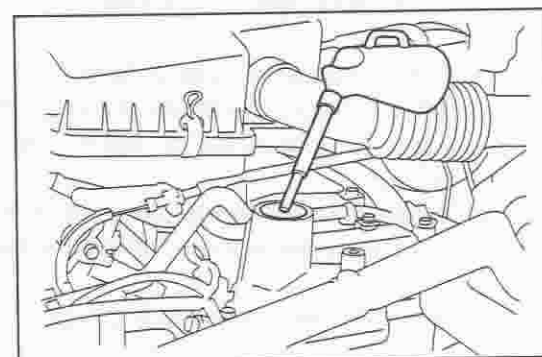

JLU00011-00010

(3) Close the oil filler cap.

WARNING:

- Securely install the oil filler cap. Failure to observe this warning will cause a fire.

(4) Check the oil level. (Refer to the "ENGINE OIL QUALITY & LEVEL CHECK".)

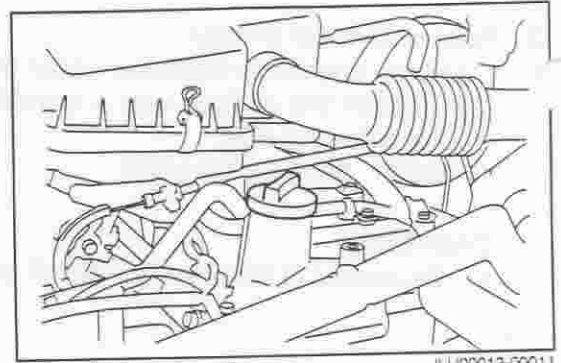

OIL PRESSURE WARNING LAMP

Check to see if the oil pressure warning lamp will be illuminated when the ignition switch is turned on.

NOTE:

- If the warning lamp will not illuminate, check to see if the bulb in the combination meter is burnt out.
- If the warning lamp is illuminated when the engine has started, perform the oil pressure check. (In advance, be sure to check that the engine oil is at a sufficient level.)



OIL PRESSURE CHECK

1. With the ignition switch turned OFF, connect the following SST to the data link connector (DLC) located at the lower section of the instrument panel on the driver's seat side.
SST: 09991-87404-000

2. Connect an engine tachometer to the terminal REV, using the following SST.
SST: 09991-87402-000

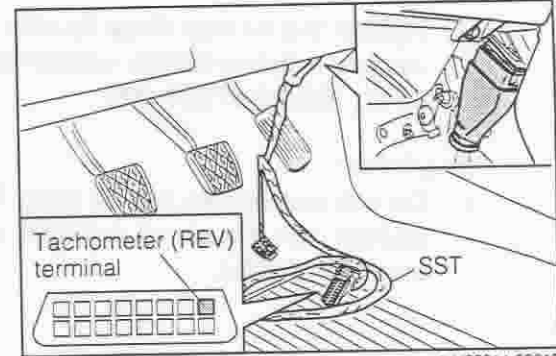

3. Disconnect the connector of the oil pressure switch.
4. Remove the oil pressure switch from the cylinder block.
5. Install the oil pressure gauge.

NOTE:

- The oil pressure gauge is available as the SST.
SST: 09990-87702-000

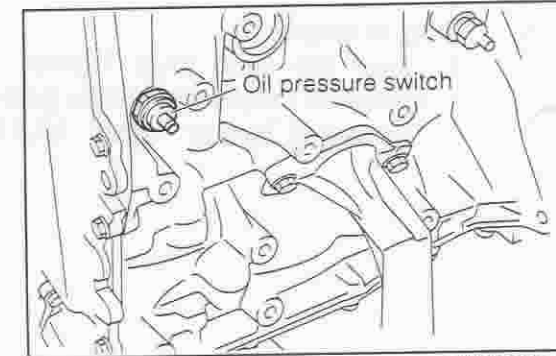

6. Measurement of oil pressure.
Start the engine and measure the oil pressure. Ensure that the oil pressure conforms to the specified value.
At 700 rpm: 39 kPa
At 3000 rpm: 225 kPa

If the measured value fails to conform to the specified value, check and repair the oil pump. Also, check to see if each oil clearance is within the specified value, as required.

When the warning lamp goes on even if the oil pressure is normal, replace the oil pressure switch.

7. Remove the oil pressure gauge.

8. Installation of oil pressure switch

- (1) Clean the oil pressure switch attaching hole of the cylinder block.

NOTE:

- Be very careful not to allow any admission of dust or the like.

- (2) Clean the threaded portion of the oil pressure switch.
- (3) Apply the following sealing agent to the threaded portion.

Sealing Agent: Locktight 525 or equivalent

NOTE:

- Utmost care must be exercised not to allow the sealing agent to get to the oil entering hole.

- (4) Install the oil pressure switch to the cylinder block.
Tightening Torque: 10.5 - 19.5 N·m

- (5) Connect the connector of the oil pressure switch.
- (6) Start the engine and check it for oil leakage. Repair the leaky point if oil leakage exists.

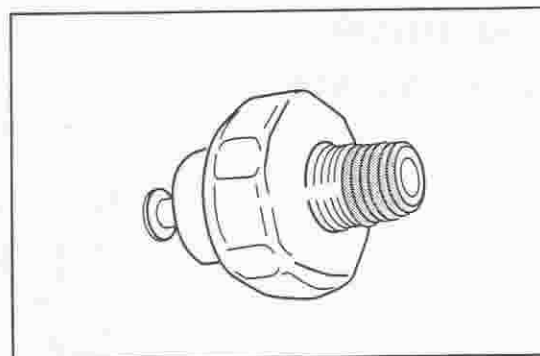

JLU00017-00016

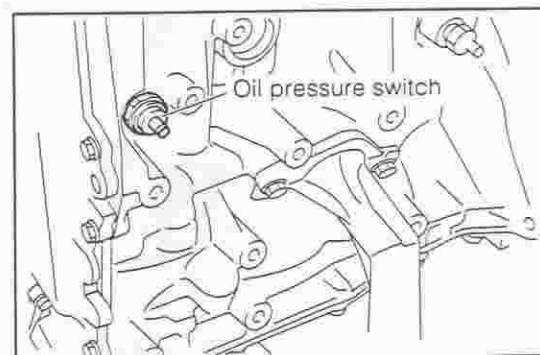

JLU00018-00017

LU-6

OIL PUMP COMPONENTS

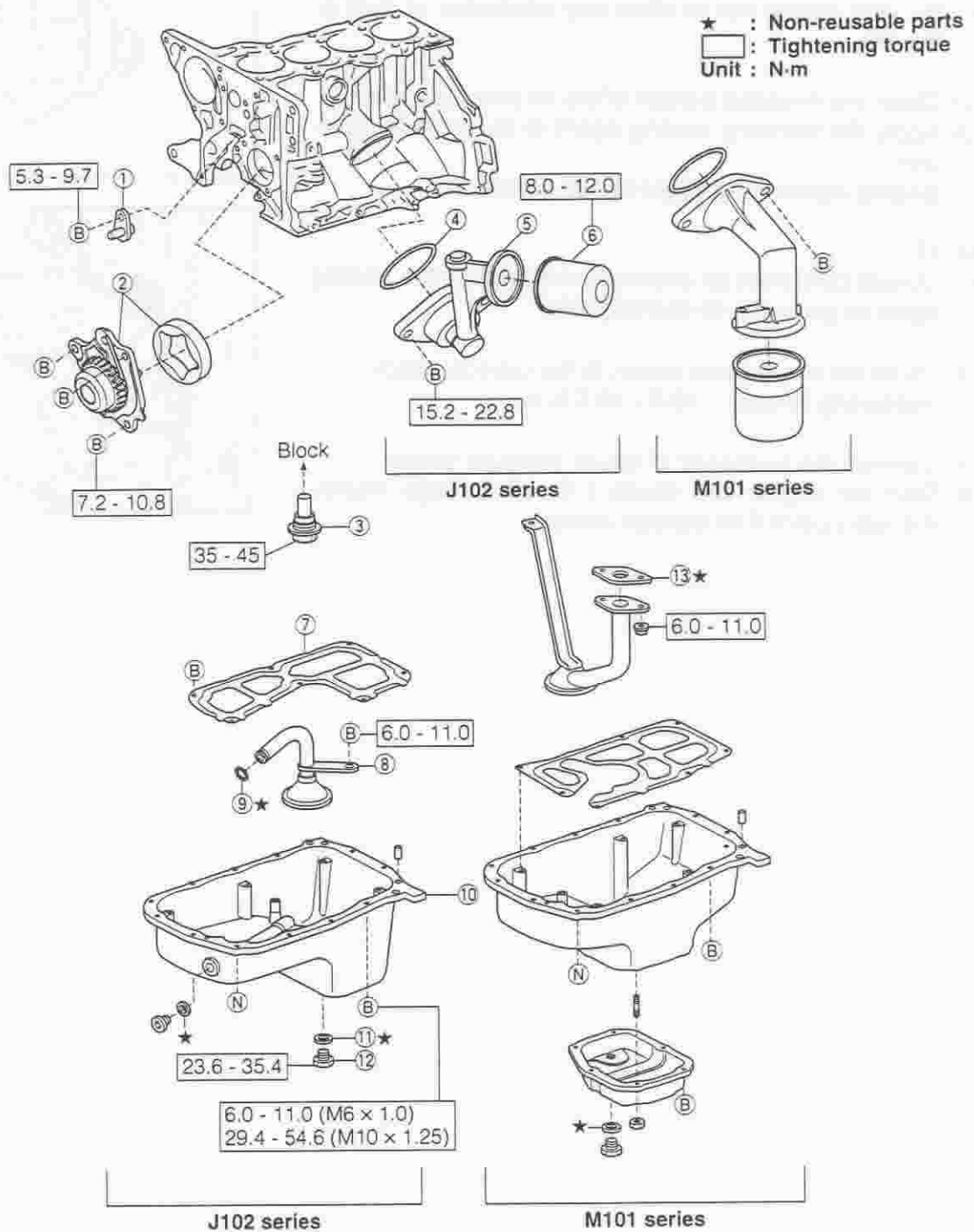

- ① Timing chain oil nozzle
- ② Oil pump assembly
- ③ Oil relief valve
- ④ O-ring
- ⑤ Oil filter bracket
- ⑥ Oil filter
- ⑦ Buckle plate

- ⑧ Oil strainer
- ⑨ O-ring
- ⑩ Oil pan
- ⑪ Drain plug gasket
- ⑫ Drain plug
- ⑬ Oil strainer gasket

REMOVAL

- Remove the oil pan retaining bolts and nuts.

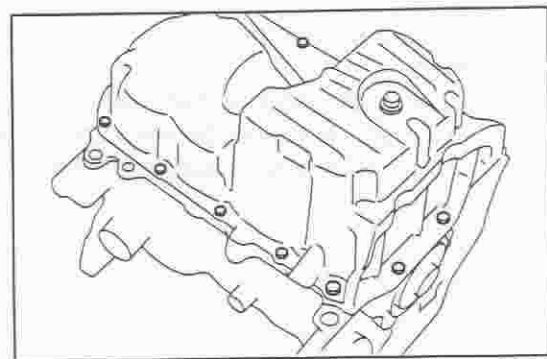

JLU00020-00019

- Detach the oil pan from the cylinder block, using the following SST.

SST: 09032-00100-000

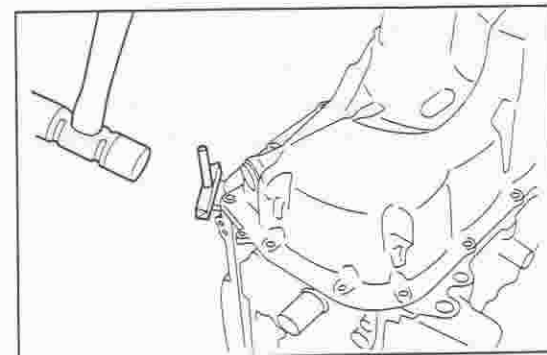

JLU00021-00020

- Remove the oil strainer and gasket. (M101 Series only)

NOTE:

- On the J102 series, the oil strainer is mounted on the oil pan.

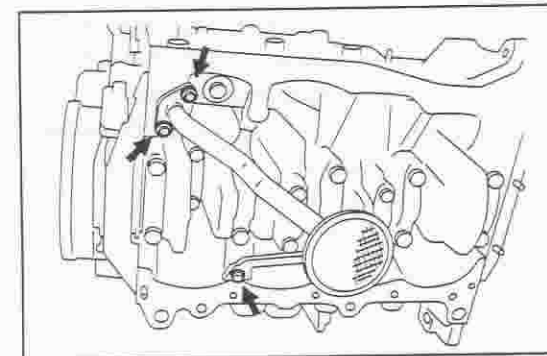

JLU00022-00021

- Remove the oil relief valve.
- Remove the timing chain. (Refer to the EM section.)

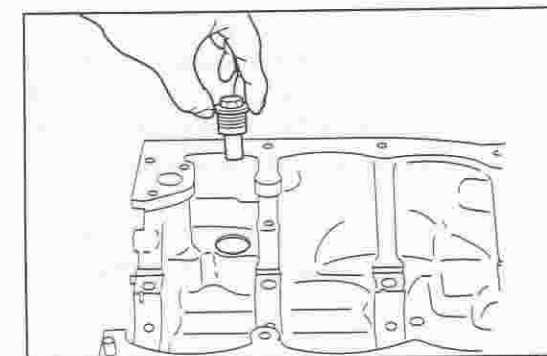

JLU00023-00022

- Remove the timing chain oil nozzle.

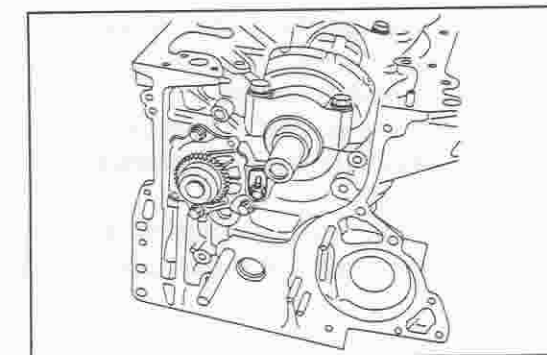

JLU00024-00023

LU-8

7. Remove the oil pump.

NOTE:

- The outer rotor is not fixed to the oil pump assembly. Hence, care must be exercised to ensure that the outer rotor will not drop during the removal.

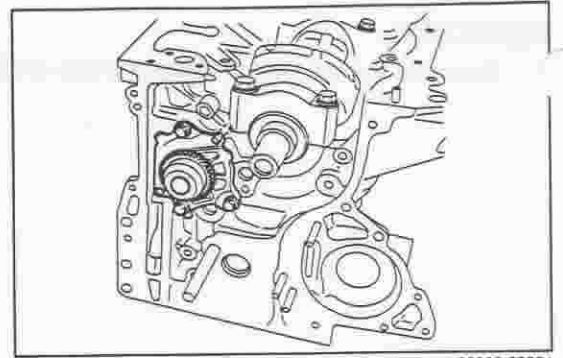

INSPECTION

1. Check of oil relief valve

Push the valve. Check to see if the valve is encountered with seizure. If the valve is seized, replace the oil relief valve.

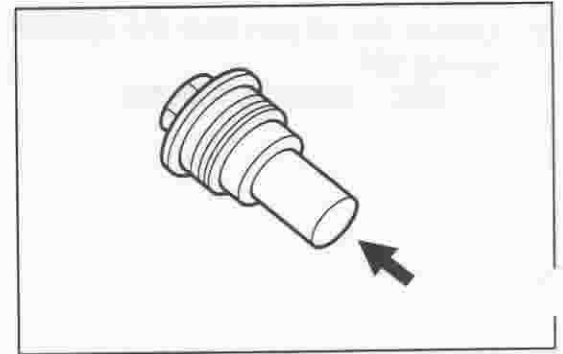

2. Check of timing chain oil nozzle

Apply compressed air to the timing chain nozzle. Check to see if the nozzle is restricted. If the nozzle restriction is not remedied, replace the timing chain oil nozzle.

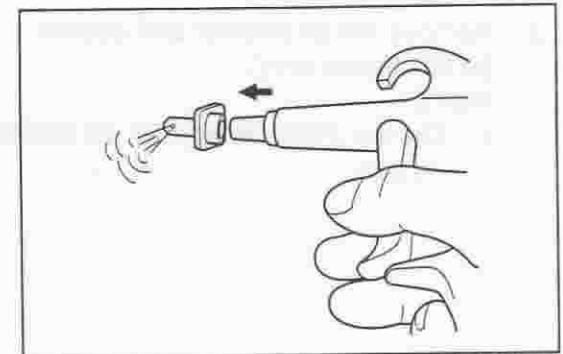

3. Check of oil pump assembly

- (1) Measure the clearance between the oil pump drive gear and the outer rotor, using a thickness gauge.
Specified Tip Clearance: 0.06 - 0.16 mm
Maximum Tip Clearance: 0.16 mm

If the tip clearance exceeds the maximum tip clearance, replace the oil pump assembly.

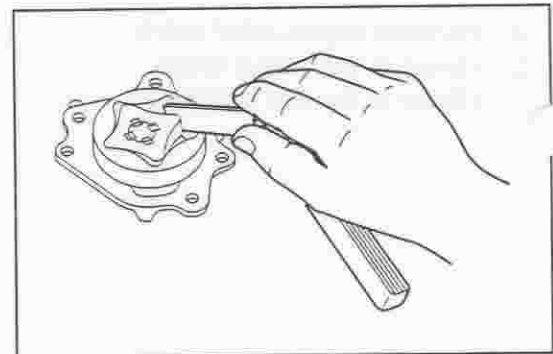

- (2) Measure the body clearance between the outer rotor and the oil pump bore of the cylinder block, using a thickness gauge.

Specified Body Clearance: 0.030 - 0.090 mm
Maximum Body Clearance: 0.15 mm

If the body clearance exceeds the maximum clearance, replace the oil pump assembly.

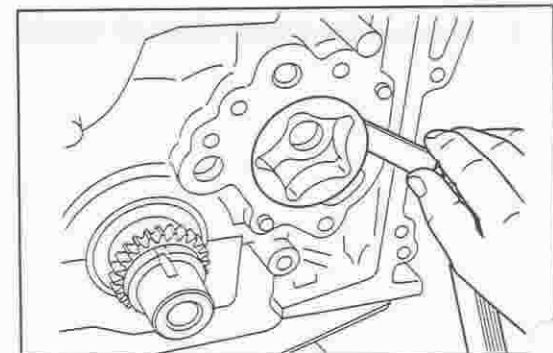

- (3) Measure the side clearance between the outer rotor and the precision straightedge, using a thickness gauge.

Specified Side Clearance: 0.100 - 0.140 mm

Maximum Side Clearance: 0.30 mm

If the side clearance exceeds the maximum clearance, replace the oil pump assembly.

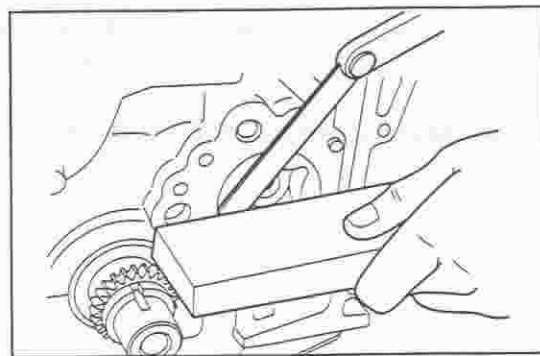

JLU00030-00029

- (4) Check to see if the oil pump turns smoothly, by turning the sprocket. If any damage is present, replace the oil pump assembly.

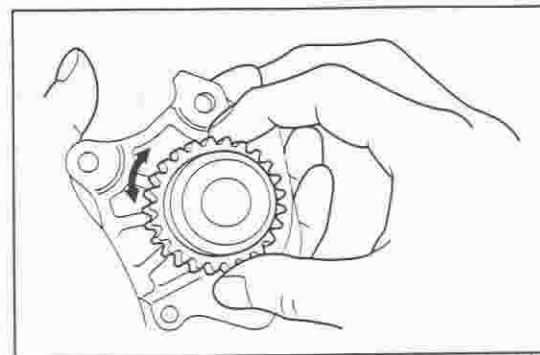

JLU00031-00030

INSTALLATION

1. Installation of oil pump

- (1) Apply engine oil to between the oil pump assembly driven gear and the outer rotor.

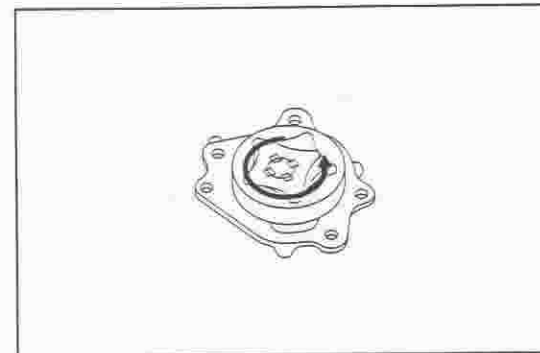

JLU00032-00031

- (2) Apply engine oil to the underside (more than 90 degrees) of the outer periphery of the oil pump rotor bore of the cylinder block.

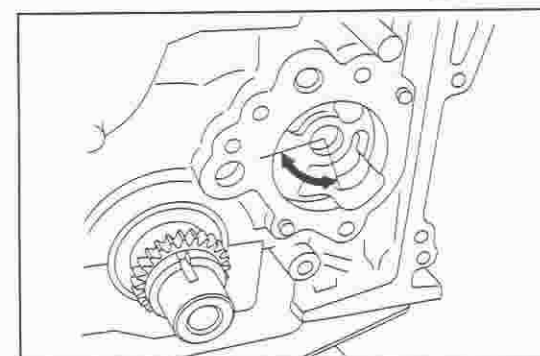

JLU00033-00032

- (3) Assemble the oil pump assembly in the cylinder block, with two location pins aligned each other.

Tightening Torque: 7.2 - 10.8 N·m

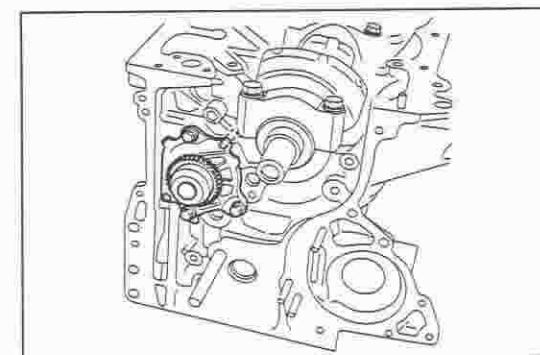

JLU00034-00033

LU-10

- (4) Turn the sprocket more than one turn so that engine oil may be circulated over the whole surface of the rotor.

NOTE:

- Make sure that the sprocket can turn smoothly.

JLU00035-00000

2. Installation of timing chain oil nozzle
Install the timing chain oil nozzle to the cylinder block.
Tightening Torque: 5.3 - 9.7 N·m

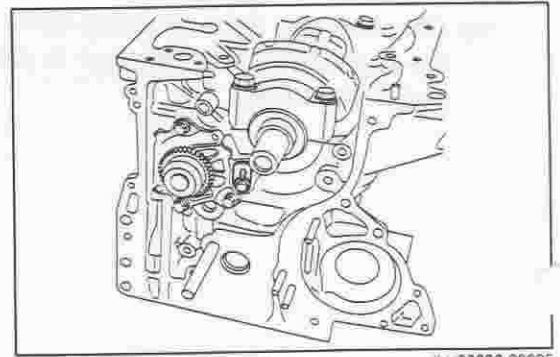

JLU00036-00035

3. Installation of oil relief valve
Install the oil relief valve to the cylinder block.
Tightening Torque: 35 - 45 N·m

NOTE:

- Make sure that no foreign matter is lodged in the oil relief valve accommodating hole.

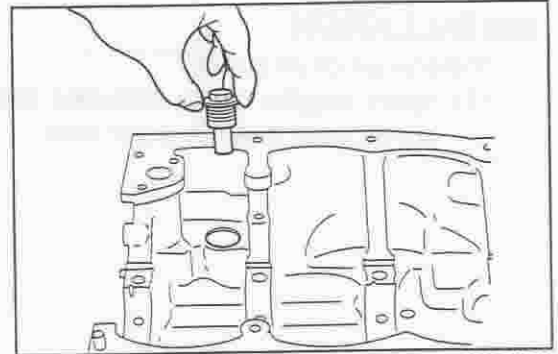

JLU00037-00036

4. Installation of oil strainer (M101 series only)
Install the oil strainer and gasket to the cylinder block.
Tightening Torque: 6.0 - 11.0 N·m

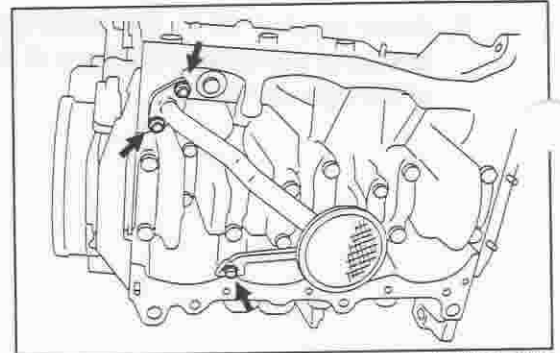

JLU00038-00037

5. Installation of oil pan
Install the oil pan to the cylinder block.
(Refer to the EM section.)

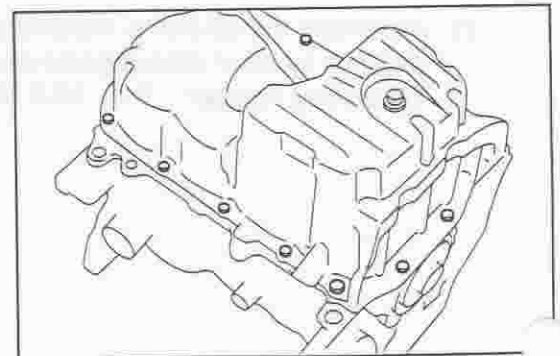

JLU00039-00038





SERVICE SPECIFICATIONS

	Grade	Capacity		
		Engine oil	SH or higher	With oil filter replacement
J102	3.2 ℓ			
Without oil filter replacement	M101			3.3 ℓ
	J102			3.0 ℓ

Oil pump	Body clearance	0.030 - 0.090 mm
	Tip clearance	0.060 - 0.160 mm
	Side clearance	0.100 - 0.140 mm
	Oil pressure	at 700 rpm at 3000 rpm
		39 kPa 225 kPa

JLUD0040-00000

SSTs

Shape	Part No.	Part name	Remarks
	09228-87201-000	Oil filter wrench	
	09990-87702-000	Oil pressure gauge	
	09032-00100-000	Oil pan seal cutter	
	09991-87402-000	Tachometer pulse pick-up wire	Measurement of engine revolution speed
	09991-87404-000	Engine control system inspection wire	Measurement of engine revolution speed

JLUD0041-00000

TIGHTENING TORQUE

Components	N·m	kgf·m	Remarks
Timing chain oil nozzle × Cylinder block	5.3 - 9.7	0.53 - 0.97	
Oil pump assembly × Cylinder block	7.2 - 10.8	0.72 - 1.08	
Oil relief valve × Cylinder block	35 - 45	3.5 - 4.5	
Oil filter bracket × Cylinder block	15.2 - 22.8	1.52 - 2.28	
Oil pressure switch × Cylinder block	10.5 - 19.5	1.05 - 1.95	
Oil filter × Oil filter bracket	8.0 - 12.0	0.8 - 1.2	
Oil strainer × Cylinder block	6.0 - 11.0	0.6 - 1.1	M101 series
Oil strainer × Oil pan	6.0 - 11.0	0.6 - 1.1	J102 series
Oil pan × Cylinder block	6.0 - 11.0	0.6 - 1.1	M6 × 1.0
	29.4 - 54.6	2.94 - 5.46	M10 × 1.25
Drain plug × Oil pan	23.6 - 35.4	2.36 - 3.54	

JLUD0042-00000