

PARTS CATALOGUE

- XT350M (3NVY) U49
XT350MC (5LJ1) CALIFORNIA
XT350M (5LJ2) CANADA
XT350M (4FC9) AUSTRALIA
-



A3

FOREWORD

This Parts Catalogue is related to the parts for the model(s) in the below frame. When you are ordering replacement parts, please refer to this Parts Catalogue and quote both part numbers and part names correctly.

XT350M(3NVY/5LJ2/4FC9),XT350MC(5LJ1)

1. Modifications or additions which have been made after issue of the Parts Catalogue will be announced in the Yamaha Parts News. It is advisable that you make necessary corrections to the Parts Catalogue according to the Yamaha Parts News.

2. Abbreviations
The Following abbreviations are used in this Parts Catalogue.

- "UR" Use specified parts number.
- "UN" Use as many as needed.
- "AP" Alternate Parts
- "LM" Local Made (Parts need to be ordered locally)
- "F#" Frame No. (Applicable machine No.)

3. Parts, which are to be supplied in an assembly, are listed with a dot(.) in front of the part name as shown below.

EXAMPLE

- CARBURETOR ASSY
- .JET, PILOT
- .NOZZLE, MAIN

4. Number of component for assembly
The numeral appearing to the right of each component part indicates the quantity of parts for each assembly unit.

EXAMPLE

PART NO.	DESCRIPTION	Q'TY	REMARKS
2F5-83310-60	FRONT FLASHER LIGHT ASSY	2	
115-83311-60	.BULB (6V-18W)	1	
1M1-83309-60	.REFLECTOR	1	

5. Applicable colors of graphics are represented in the "REMARKS" as shown below.

PART NO.	DESCRIPTION	Q'TY	REMARKS
2N4-24110-00-X5	.FUEL TANK COMP.	2	MXR
3J1-24240-10	.GRAPHIC, FUEL TANK	1	for MXR

6. Applicable Serial No.

Engine Serial No.

Frame Serial No.

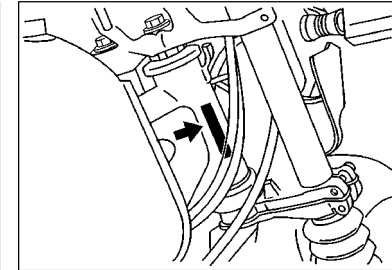
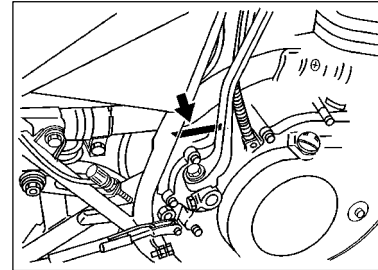

7. Note that the illustrations for reference in funding parts numbers, not to be used for assembling. When assembling, please use the applicable service manual.
8. The asterisk (*) before a reference number indicates modification items after the first edition.

MODEL LABEL

(1) A label called "Model Label" is affixed in the location as indicated in (3) below.
 When using this parts catalogue, please be sure to cross-refer the "model code – production code No." in the catalogue to the "model code – production code No." indicated on the Model Label affixed onto the product concerned.

(2) "Model Label" Indication

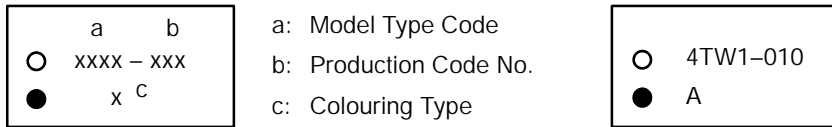

(3) Model Label Affixing Location

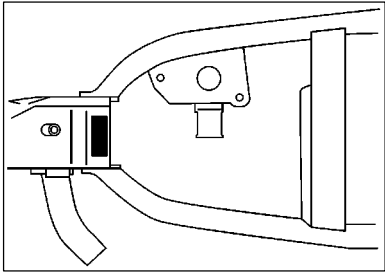

(4) Model Code – Production Code Number of Model Listed in This Parts Catalog

Model Code	Production Code No.	Country (destination)	Model Code	Production Code No.	Country (destination)
3NVY	010	U49			
5LJ1	010	CALIFORNIA			
5LJ2	010	CANADA			
4FC9	010	AUSTRALIA			

(5) Colouring Information

Model Code	Colouring type code	Colour code	Colour Name	Abbreviation
3NVY	A	0206	PURPLISH WHITE SOLID 1	PWS1
5LJ1				
5LJ2				
4FC9				

FIG. 1 CYLINDER HEAD

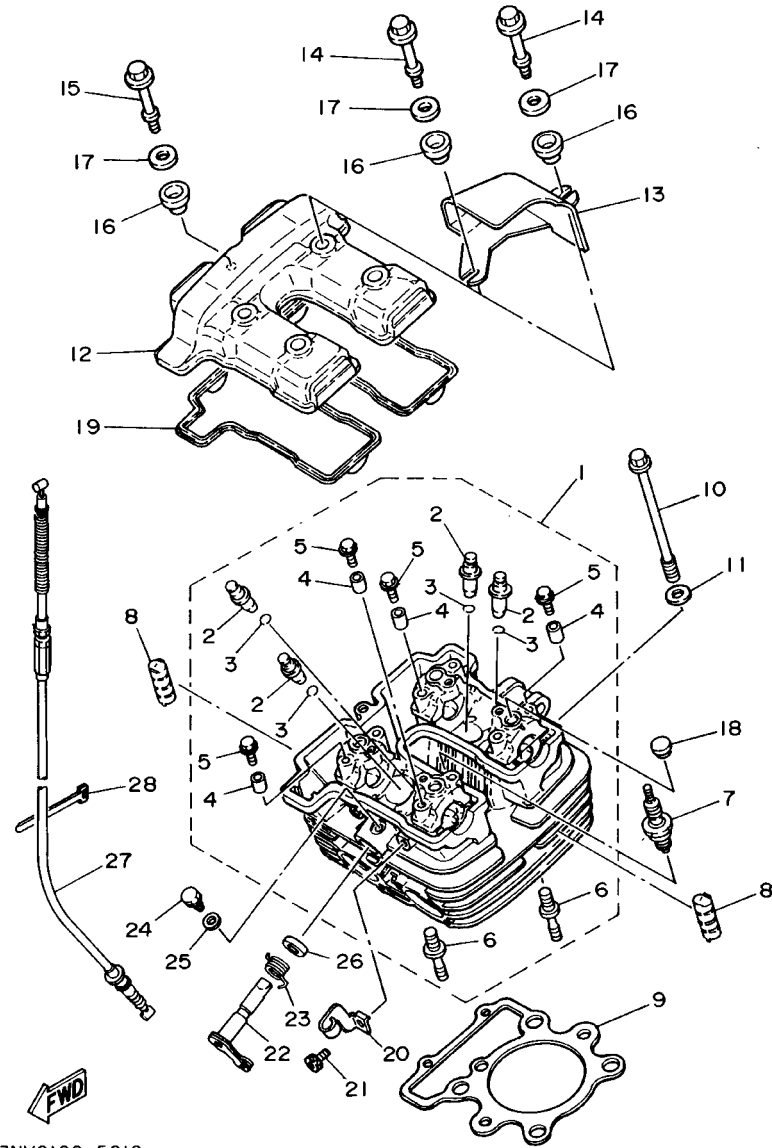

REF. NO.	PART NO.	DESCRIPTION	3NVJ	5LJ1	5LJ2	4FC9	REMARKS
1	55V-11101-01	CYLINDER HEAD ASSY	1	1	1	1	
2	30X-11133-10	.GUIDE, INTAKE VALVE	4	4	4	4	
3	93440-10109	.CIRCLIP	4	4	4	4	
4	99510-08016	.PIN, DOWEL	8	8	8	8	
5	90105-06153	.BOLT, WASHER BASED	8	8	8	8	
6	90116-10378	.BOLT, STUD	2	2	2	2	
7	94701-00157	PLUG, SPARK (NGK D8EA)	1	1			UR
	94701-00181	PLUG, SPARK (ND X24ES-U)	1	1			UR
	94701-00333	PLUG, SPARK (NGK DR8EA)			1	1	
8	30X-11161-00	ABSORBER 1	4	4	4	4	
9	55V-11181-00	GASKET, CYLINDER HEAD 1	1	1	1	1	
10	90105-10608	BOLT, WASHER BASED	4	4	4	4	
11	90201-101A4	WASHER, PLATE	4	4	4	4	
12	30X-11191-01	COVER, CYLINDER HEAD 1	1	1	1	1	
13	30X-11192-01	COVER, CYLINDER HEAD 2	1	1	1	1	
14	90109-064F0	BOLT	4	4	4	4	
15	90109-06584	BOLT	1	1	1	1	
16	2GH-1111G-00	RUBBER, MOUNT 1	5	5	5	5	
17	90209-11262	WASHER	5	5	5	5	
18	90338-11125	PLUG	4	4	4	4	
19	30X-11193-01	GASKET, HEAD COVER 1	1	1	1	1	
20	30X-12283-00	BRACKET, DECOMPRESSION	1	1	1	1	
21	91317-06012	BOLT	1	1	1	1	
22	30X-12288-00	CAM, DECOMPRESSION	1	1	1	1	
23	90508-18606	SPRING, TORSION	1	1	1	1	
24	90109-06418	BOLT	1	1	1	1	
25	90430-06014	GASKET	1	1	1	1	

FIG. 1 CYLINDER HEAD

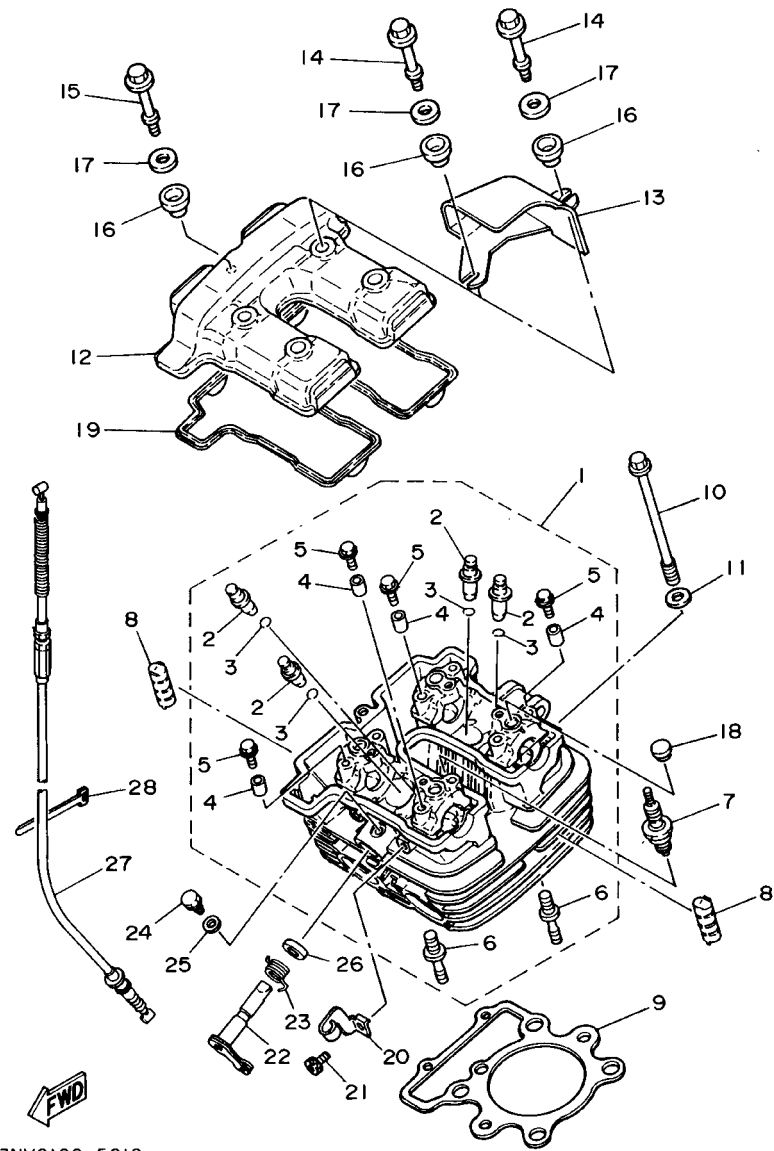

REF. NO.	PART NO.	DESCRIPTION	3NVY	5LJ1	5LJ2	4FC9	REMARKS
26	93102-12321	OIL SEAL	1	1	1	1	
27	30X-12292-00	CABLE, DECOMPRESSION	1	1	1	1	
28	437-83936-01	BAND, SWITCH CORD	1	1	1	1	

FIG. 2 CYLINDER

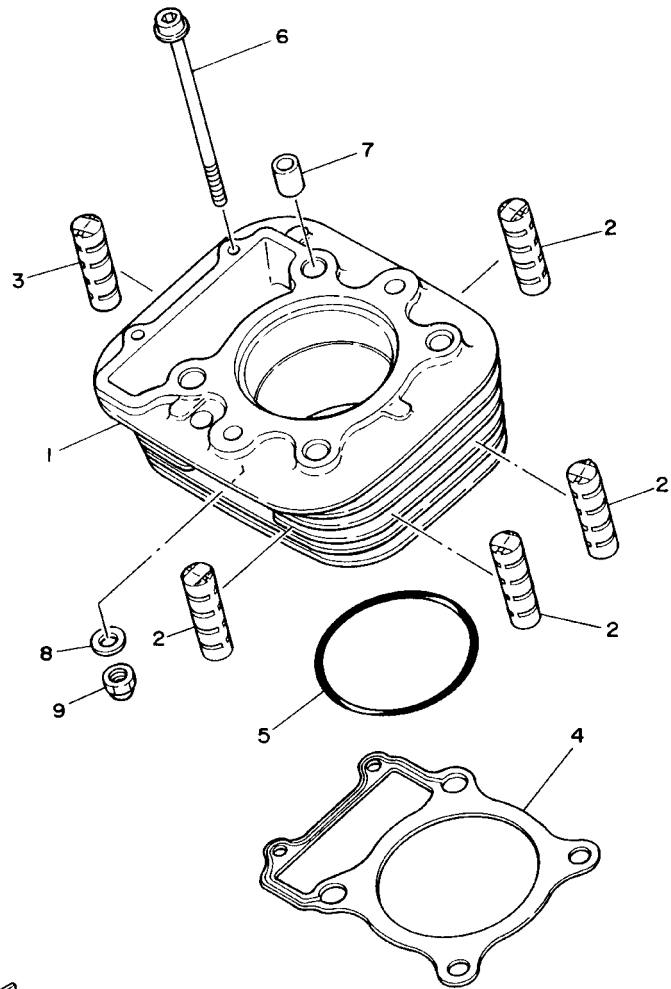

REF. NO.	PART NO.	DESCRIPTION	3NVY	5LJ1	5LJ2	4FC9	REMARKS
1	55V-11310-03	CYLINDER	1	1	1	1	
2	3Y1-11162-00	ABSORBER 2	4	4	4	4	
3	30X-11127-00	ABSORBER 3	1	1	1	1	
4	4DR-11351-00	GASKET, CYLINDER	1	1	1	1	
5	93210-89447	O-RING	1	1	1	1	
<hr/>							
6	90105-06406	BOLT, WASHER BASED	2	2	2	2	
7	99530-14016	PIN, DOWEL	2	2	2	2	
8	90201-087G0	WASHER, PLATE	2	2	2	2	
9	90176-08026	NUT, CROWN	2	2	2	2	
<hr/>							
<hr/>							
<hr/>							
<hr/>							
<hr/>							



IET171-8020

FIG. 3 CRANKSHAFT. PISTON

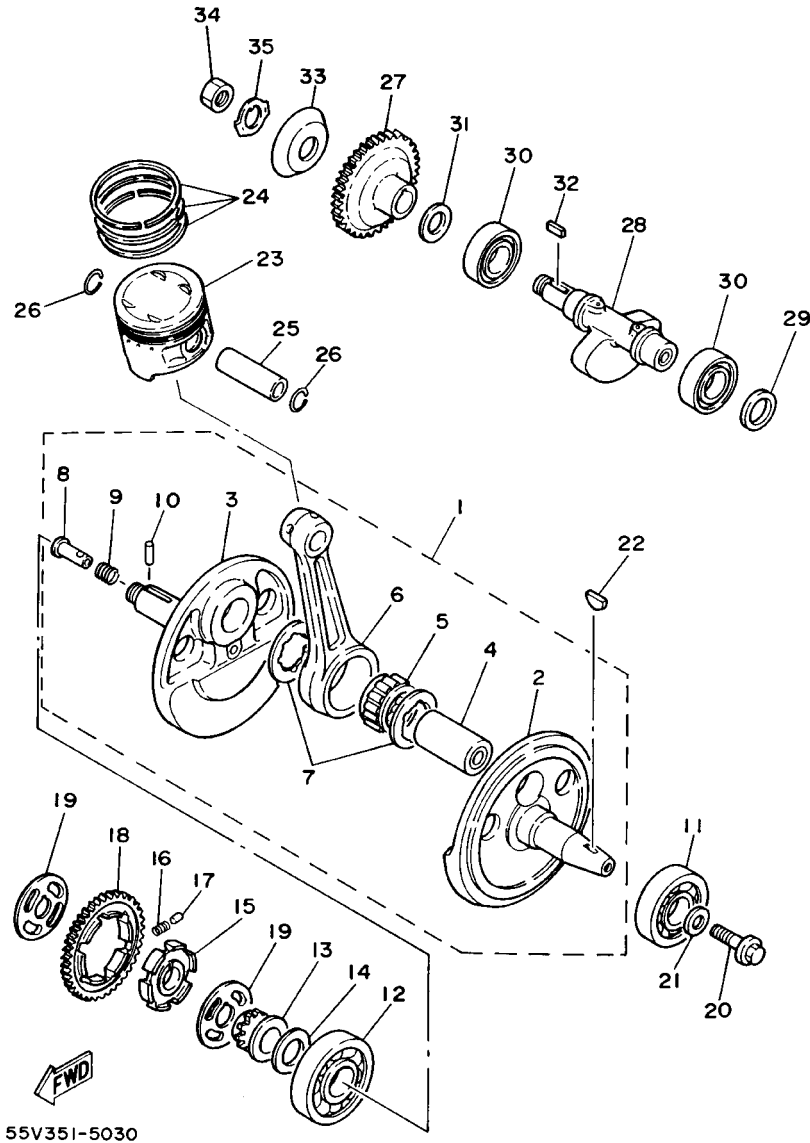

REF. NO.	PART NO.	DESCRIPTION	3NVY	5LJ1	5LJ2	4FC9	REMARKS
1	55V-11400-02	CRANKSHAFT ASSY	1	1	1	1	
2	55V-11412-00	.CRANK 1	1	1	1	1	
3	55V-11422-01	.CRANK 2	1	1	1	1	
4	51Y-11681-00	.PIN, CRANK 1	1	1	1	1	
5	93310-738N1	.BEARING	1	1	1	1	
6	51Y-11651-01	.ROD, CONNECTING	1	1	1	1	
7	90209-38266	.WASHER	2	2	2	2	
8	90240-07105	.PIN, CLEVIS	1	1	1	1	
9	90501-07629	.SPRING, COMPRESSION	1	1	1	1	
10	93602-13177	.PIN, DOWEL	1	1	1	1	
11	93306-30630	BEARING	1	1	1	1	
12	93306-30622	BEARING (6306SH4 SPECIAL)	1	1	1	1	
13	30X-11549-00	SPROCKET, CAM CHAIN	1	1	1	1	
14	90209-23242	WASHER	1	1	1	1	
15	30X-11496-00	BOSS, BUFFER	1	1	1	1	
16	90501-22721	SPRING, COMPRESSION	6	6	6	6	
17	93605-10090	PIN, DOWEL	3	3	3	3	
18	51Y-11531-00	GEAR, BALANCE WT	1	1	1	1	
19	30X-11565-00	WASHER, BEARING COVER	2	2	2	2	
20	90105-10290	BOLT, WASHER BASED	1	1	1	1	
21	90201-10508	WASHER, PLATE	1	1	1	1	
22	90280-05013	KEY, WOODRUFF	1	1	1	1	
23	55V-11631-01-Y0	PISTON (STD)	1	1	1	1	
	55V-11636-01	PISTON (0.50MM O/S)	1	1	1	1	AP
	55V-11638-01	PISTON (1.00MM O/S)	1	1	1	1	AP
24	55V-11610-00	PISTON RING SET (STD)	1	1	1	1	
	55V-11610-20	PISTON RING SET (0.50MM O/S)	1	1	1	1	AP

FIG. 3 CRANKSHAFT. PISTON

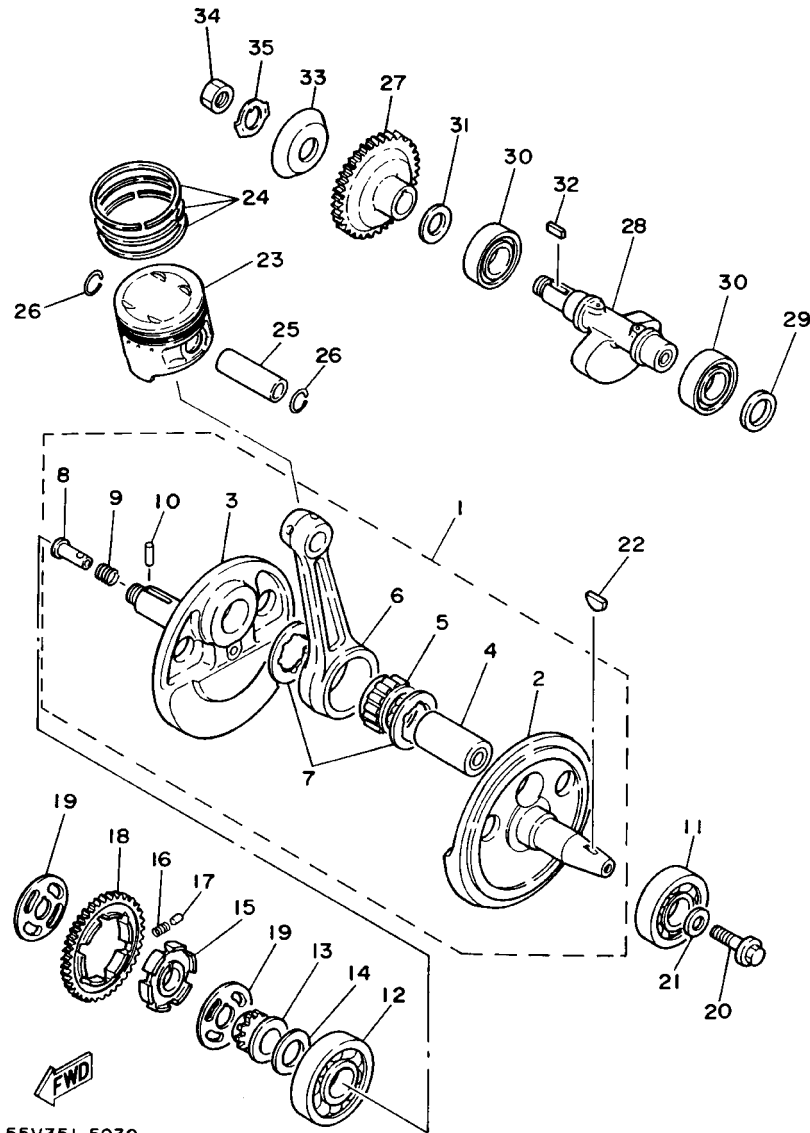

REF. NO.	PART NO.	DESCRIPTION	3NVY	5LJ1	5LJ2	4FC9	REMARKS
24	55V-11610-40	PISTON RING SET (1.00MM O/S)	1	1	1	1	AP
25	55V-11633-00	PIN, PISTON	1	1	1	1	
26	93450-19095	CIRCLIP	2	2	2	2	
27	51Y-11536-00	GEAR, DRIVE	1	1	1	1	
28	55V-11454-00	WEIGHT 1	1	1	1	1	
29	93101-25106	OIL SEAL	1	1	1	1	
30	93306-20532	BEARING	2	2	2	2	
31	90201-207G6	WASHER, PLATE	1	1	1	1	
32	90282-05034	KEY, STRAIGHT	1	1	1	1	
33	34K-11145-00	PLATE, BREATHER 2	1	1	1	1	
34	90170-16326	NUT	1	1	1	1	
35	90215-16221	WASHER, LOCK	1	1	1	1	

FIG. 4 VALVE

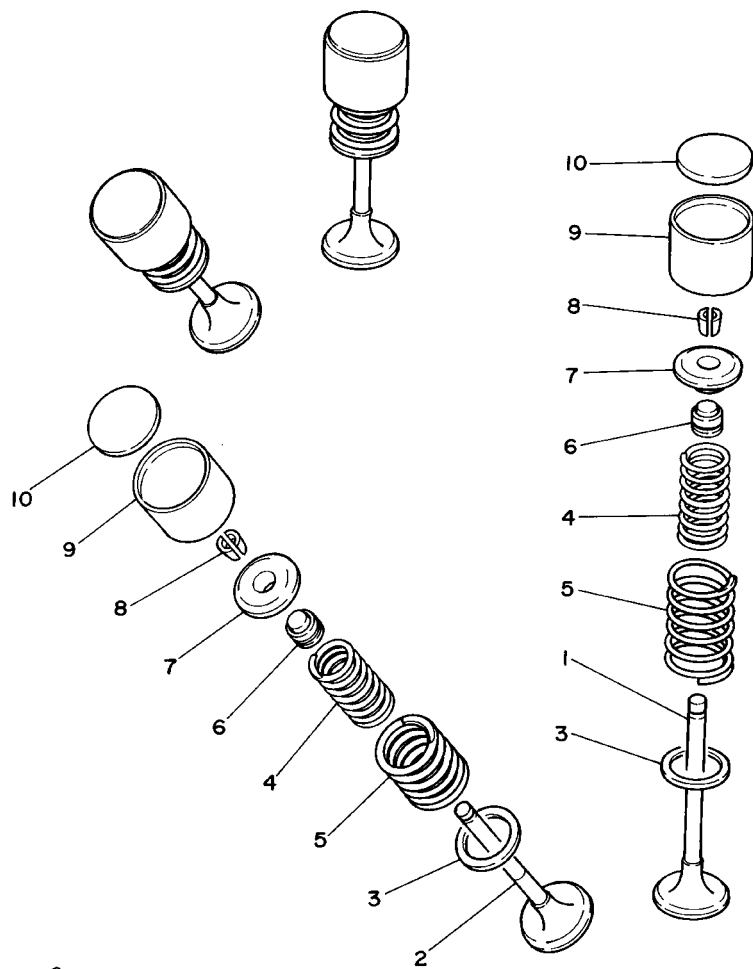

REF. NO.	PART NO.	DESCRIPTION	3NVY	5LJ1	5LJ2	4FC9	REMARKS
1	30X-12111-01	VALVE, INTAKE	2	2	2	2	
2	30X-12121-00	VALVE, EXHAUST	2	2	2	2	
3	26H-12116-00	SEAT, VALVE SPRING	4	4	4		
4	30X-12113-00	SPRING, VALVE INNER	4	4	4	4	
5	30X-12114-00	SPRING, VALVE OUTER	4	4	4	4	
6	51Y-12119-00	SEAL, VALVE STEM	4	4	4	4	
7	30X-12117-00	RETAINER, VALVE SPRING	4	4	4	4	
8	30X-12118-00	COTTER, VALVE	8	8	8	8	
9	26H-12153-00-J0	LIFTER, VALVE(O/S)	4	4	4	4	
	26H-12153-00-Y0	LIFTER, VALVE	4	4	4	4	
10	26H-12168-00	PAD, ADJUSTING (2.00)	4	4	4	4	UR
	26H-12168-20	PAD, ADJUSTING (2.05)	4	4	4	4	UR
	26H-12168-40	PAD, ADJUSTING (2.10)	4	4	4	4	UR
	26H-12168-60	PAD, ADJUSTING (2.15)	4	4	4	4	UR
	26H-12168-80	PAD, ADJUSTING (2.20)	4	4	4	4	UR
	26H-12168-A0	PAD, ADJUSTING (2.25)	4	4	4	4	UR
	26H-12168-F0	PAD, ADJUSTING (2.30)	4	4	4	4	UR
	26H-12168-H0	PAD, ADJUSTING (2.35)	4	4	4	4	UR
	26H-12168-K0	PAD, ADJUSTING (2.40)	4	4	4	4	UR
	26H-12168-M0	PAD, ADJUSTING (2.45)	4	4	4	4	UR
	26H-12168-R0	PAD, ADJUSTING (2.50)	4	4	4	4	UR
	26H-12168-U0	PAD, ADJUSTING (2.55)	4	4	4	4	UR
	26H-12168-W0	PAD, ADJUSTING (2.60)	4	4	4	4	UR
	26H-12168-Y0	PAD, ADJUSTING (2.65)	4	4	4	4	UR
	26H-12169-10	PAD, ADJUSTING (2.70)	4	4	4	4	UR
	26H-12169-30	PAD, ADJUSTING (2.75)	4	4	4	4	UR
	26H-12169-50	PAD, ADJUSTING (2.80)	4	4	4	4	UR



57T110-6040



57T110-6040

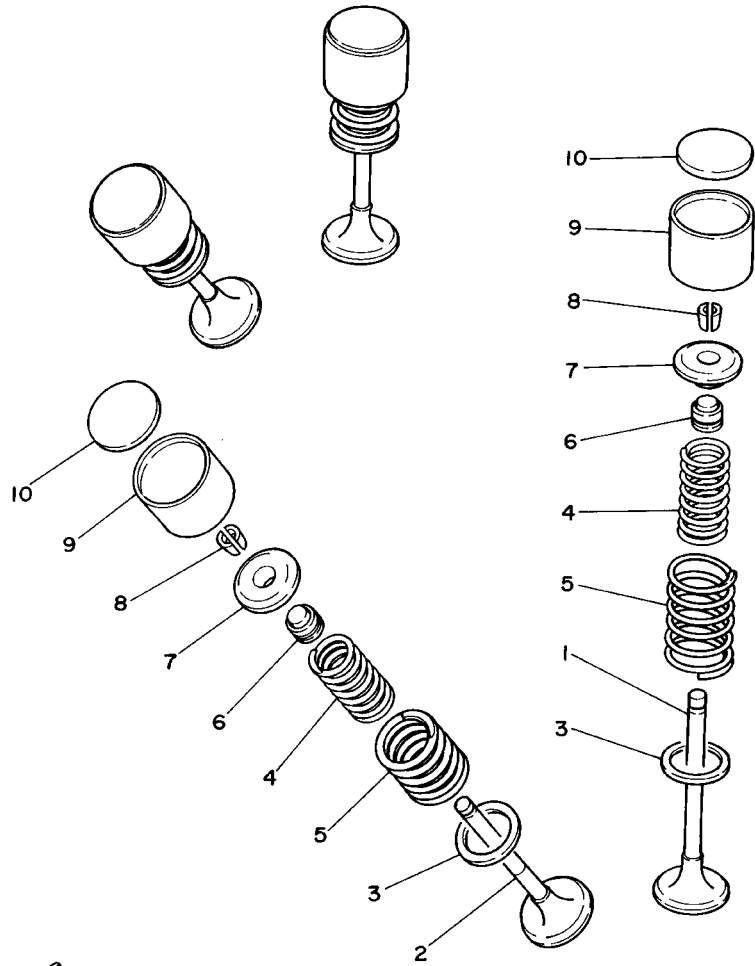
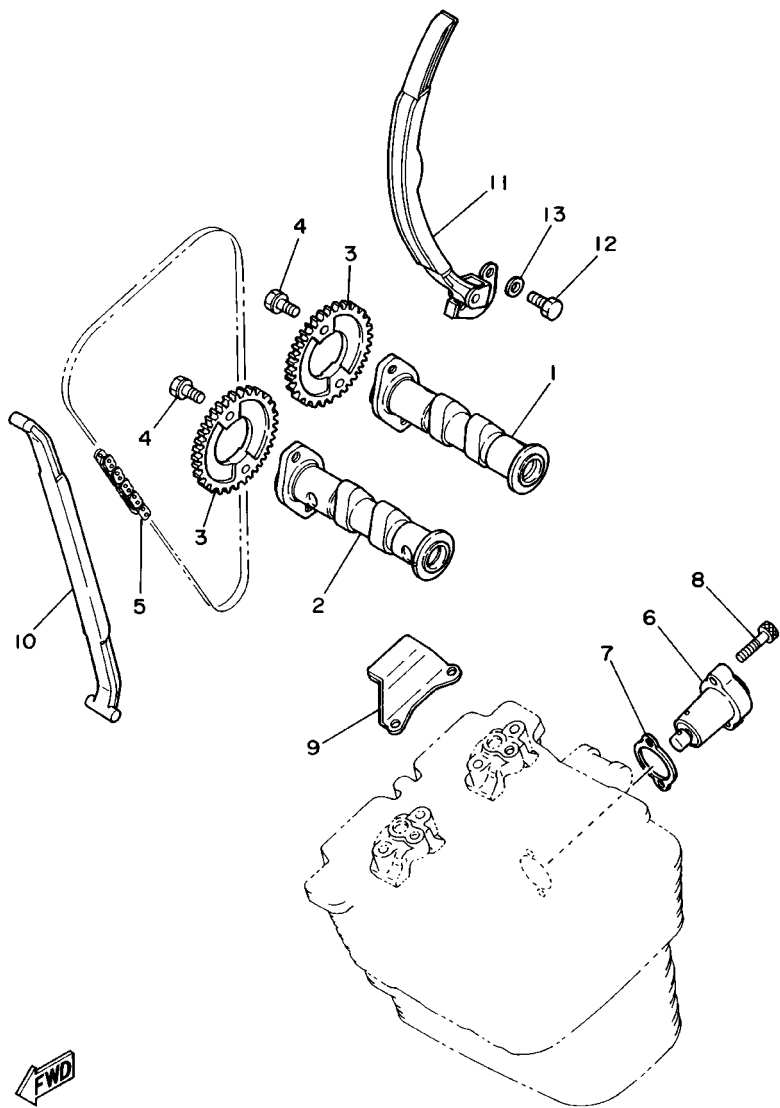

FIG. 4 VALVE

REF. NO.	PART NO.	DESCRIPTION	3NVY	5LJ1	5LJ2	4FC9	REMARKS
10	26H-12169-70	PAD, ADJUSTING (2.85)	4	4	4	4	UR
	26H-12169-90	PAD, ADJUSTING (2.90)	4	4	4	4	UR
	26H-12169-E0	PAD, ADJUSTING (2.95)	4	4	4	4	UR
	26H-12169-G0	PAD, ADJUSTING (3.00)	4	4	4	4	UR
	26H-12169-J0	PAD, ADJUSTING (3.05)	4	4	4	4	UR
	26H-12169-L0	PAD, ADJUSTING (3.10)	4	4	4	4	UR
	26H-12169-N0	PAD, ADJUSTING (3.15)	4	4	4	4	UR
	26H-12169-T0	PAD, ADJUSTING (3.20)	4	4	4	4	UR

FIG. 5 CAMSHAFT. CHAIN



REF. NO.	PART NO.	DESCRIPTION	3NVY	5LJ1	5LJ2	4FC9	REMARKS
1	48Y-12171-00	CAMSHAFT 1	1	1	1	1	
2	48Y-12181-00	CAMSHAFT 2	1	1	1	1	
3	30X-12176-00	SPROCKET, CAM CHAIN	2	2	2	2	
4	90105-07515	BOLT, WASHER BASED	4	4	4	4	
5	94590-91136	CHAIN (79RH2015-136M)	1	1	1	1	
6	30X-12210-00	TENSIONER ASSY, CAM CHAIN	1	1	1	1	
7	4FM-12213-00	GASKET, TENSIONER CASE	1	1	1	1	
8	91317-06025	BOLT	2	2	2	2	
9	30X-12241-00	GUIDE, STOPPER 2	1	1	1	1	
10	30X-12251-00	DAMPER, CHAIN 1	1	1	1	1	
11	30X-12252-01	DAMPER, CHAIN 2	1	1	1	1	
12	97027-06016	BOLT	2	2	2	2	
13	92907-06600	WASHER, PLATE	2	2	2	2	



30X010-3050

FIG. 6 OIL PUMP

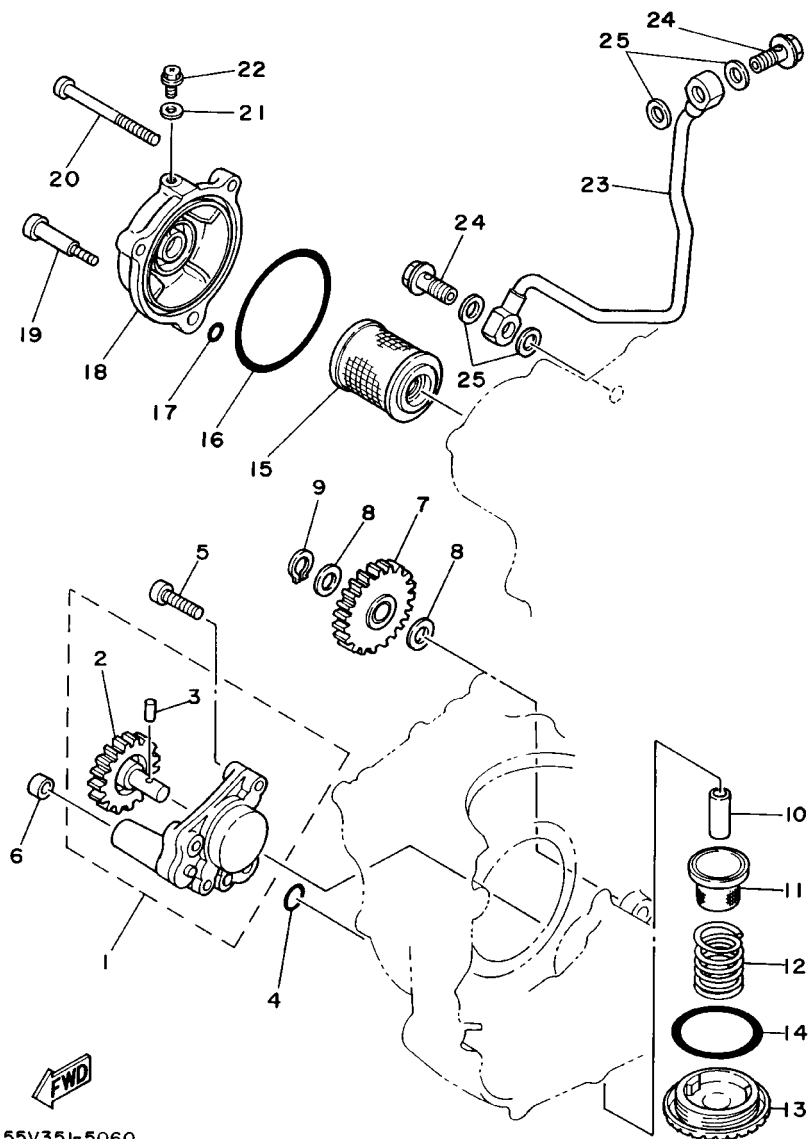

55V351-5060

REF. NO.	PART NO.	DESCRIPTION	3NVY	5LJ1	5LJ2	4FC9	REMARKS
1	30X-13300-00	OIL PUMP ASSY	1	1	1	1	
2	3Y6-13326-01	.GEAR, PUMP DRIVEN 2 (23T)	1	1	1	1	
3	93603-12030	.PIN, DOWEL	1	1	1	1	
4	93210-10096	O-RING	1	1	1	1	
5	98507-06025	SCREW, PAN HEAD	3	3	3	3	
6	90430-06156	GASKET	1	1	1	1	
7	30X-13341-00	GEAR, OIL PUMP IDLE	1	1	1	1	
8	90201-10119	WASHER, PLATE	2	2	2	2	
9	99009-10400	CIRCLIP	1	1	1	1	
10	3Y1-13416-01	PIPE, OIL 1	1	1	1	1	
11	51Y-13411-00	STRAINER, OIL	1	1	1	1	
12	90501-18576	SPRING, COMPRESSION	1	1	1	1	
13	30X-15351-00	PLUG, DRAIN	1	1	1	1	
14	93210-347A1	O-RING	1	1	1	1	
15	5H0-13440-00	ELEMENT ASSY, OIL CLEANER	1	1	1	1	
16	93210-64297	O-RING	1	1	1	1	
17	93210-07135	O-RING	1	1	1	1	
18	3DC-13447-00	COVER, OIL ELEMENT	1	1	1	1	
19	90109-06419	BOLT	1	1	1	1	
20	91317-06065	BOLT	2	2	2	2	
21	90430-05126	GASKET	1	1	1	1	
22	90149-05110	SCREW	1	1	1	1	
23	55V-13161-01	PIPE, DELIVERY 1	1	1	1	1	
24	90401-10034	BOLT, UNION	2	2	2	2	
25	90430-10188	GASKET	4	4	4	4	

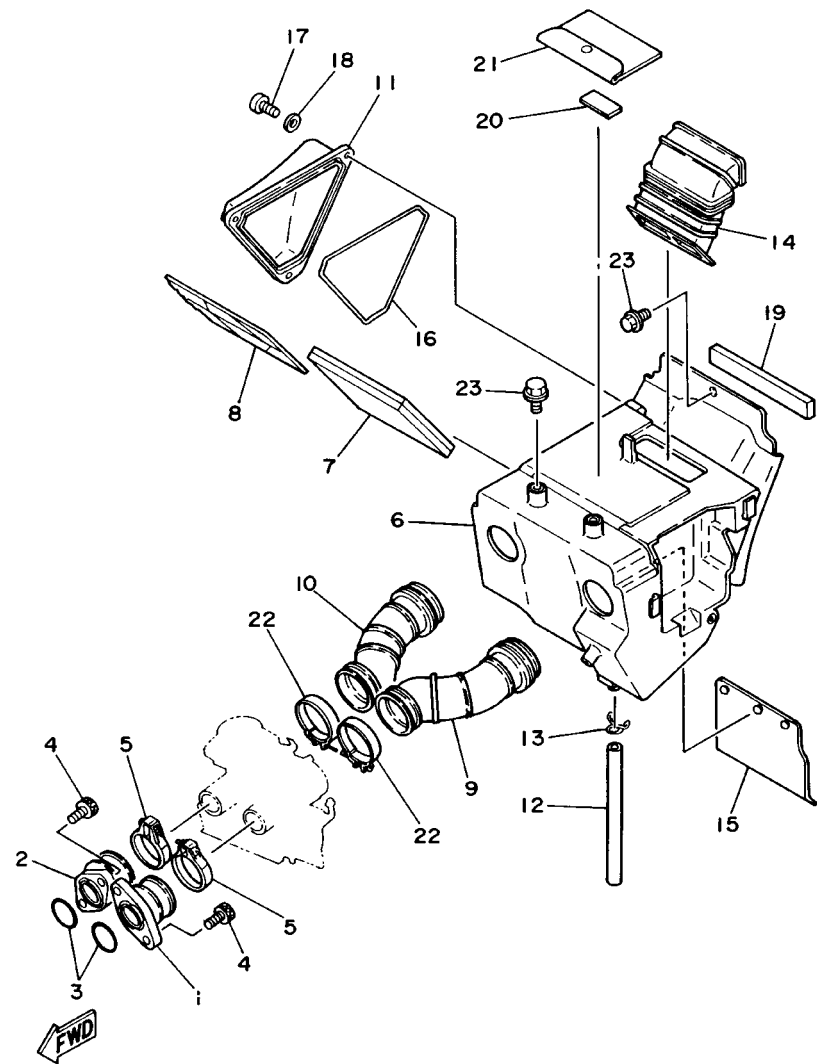

30X010-3070

FIG. 7 INTAKE

REF. NO.	PART NO.	DESCRIPTION	3NVY	5LJ1	5LJ2	4FC9	REMARKS
1	55V-13586-01	JOINT, CARBURETOR 1	1	1	1	1	
2	42U-13596-01	JOINT, CARBURETOR 2	1	1	1	1	
3	93210-30611	O-RING	2	2	2	2	
4	91317-06020	BOLT	4	4	4	4	
5	1HX-13575-00	BAND	2	2	2	2	
6	30X-14401-00	AIR CLEANER CASE ASSY	1	1	1	1	
7	30X-14451-00	ELEMENT, AIR CLEANER	1	1	1	1	
8	30X-14458-00	GUIDE	1	1	1	1	
9	30X-14453-01	JOINT, AIR CLEANER 1	1	1	1	1	
10	30X-14454-01	JOINT	1	1	1	1	
11	30X-14412-00	CAP, CLEANER CASE 1	1	1	1	1	
12	91A20-07018	TUBE, FLEXIBLE VINYL	1	1	1	1	
13	90467-13042	CLIP	1	1	1	1	
14	30X-14437-00	DUCT	1	1	1		
	55V-14437-00	DUCT				1	
15	30X-21621-00	FLAP	1	1	1	1	
16	2GV-14452-00	SEAL	1	1	1	1	
17	98507-05014	SCREW, PAN HEAD	3	3	3	3	
18	92907-05600	WASHER, PLATE	3	3	3	3	
19	30X-14426-00	DAMPER 2	1	1	1	1	
20	4K5-2814E-10	HOOK	1	1	1	1	
21	4U7-28186-00	POUCH	1	1	1	1	
22	90460-49058	CLAMP, HOSE	2	2	2	2	
23	95807-06012	BOLT, FLANGE	3	3	3	3	

FIG. 8 CARBURETOR

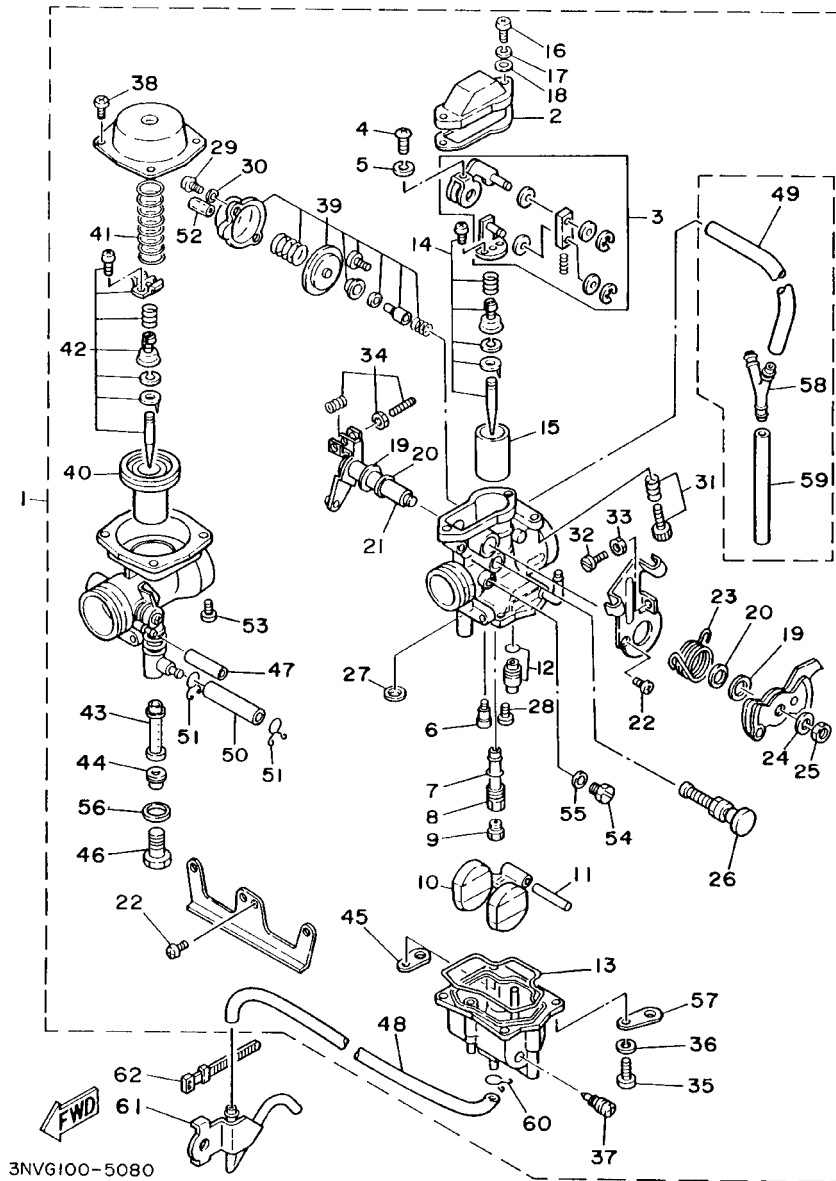

REF. NO.	PART NO.	DESCRIPTION	3NVJ	5LJ1	5LJ2	4FC9	REMARKS
1	57T-14301-04	CARBURETOR ASSY 1	1		1		
	56R-14301-04	CARBURETOR ASSY 1		1			
2	30X-14198-00	.GASKET	1	1	1		
3	30X-14203-00	.CABLE CONNECTOR SET	1	1	1		
4	98580-04015	.SCREW, PAN HEAD	1	1	1		
5	92990-04100	.WASHER, SPRING	1	1	1		
6	30X-14342-21	.JET, PILOT (# 42)	1	1	1		
7	360-24512-00	.GASKET	1	1	1		
8	51Y-14341-00	.NOZZLE, MAIN	1	1	1		
9	288-14343-63	.JET, MAIN (#125)	1	1	1		
10	5Y1-14385-00	.FLOAT	1	1	1		
11	689-14386-00	.PIN, FLOAT	1	1	1		
12	1JK-14107-01	.NEEDLE VALVE SET	1	1	1		
13	30X-14384-00	.GASKET, FLOAT CHAMBER	1	1	1		
14	57T-1490J-10	.NEEDLE SET	1	1			
	56R-1490J-10	.NEEDLE SET		1			
15	30X-14312-35	.VALVE, THROTTLE 1	1		1		
	56R-14312-35	.VALVE, THROTTLE 1		1			
16	98501-04016	.SCREW, PAN HEAD	2	2	2		
17	92901-04100	.WASHER, SPRING	2	2	2		
18	92901-04600	.WASHER, PLATE	2	2	2		
19	5Y1-14357-00	.WASHER, PLAIN	2	2	2		
20	5Y1-14572-00	.PLATE, STAY	2	2	2		
21	1LN-14930-00	.THROTTLE SHAFT ASSY	1	1	1		
22	97801-05010	.SCREW, PAN HEAD	6	6	6		
23	30X-14131-00	.SPRING, THROTTLE VALVE	1	1	1		
24	5Y1-14356-00	.WASHER, SPRING	1	1	1		

FIG. 8 CARBURETOR

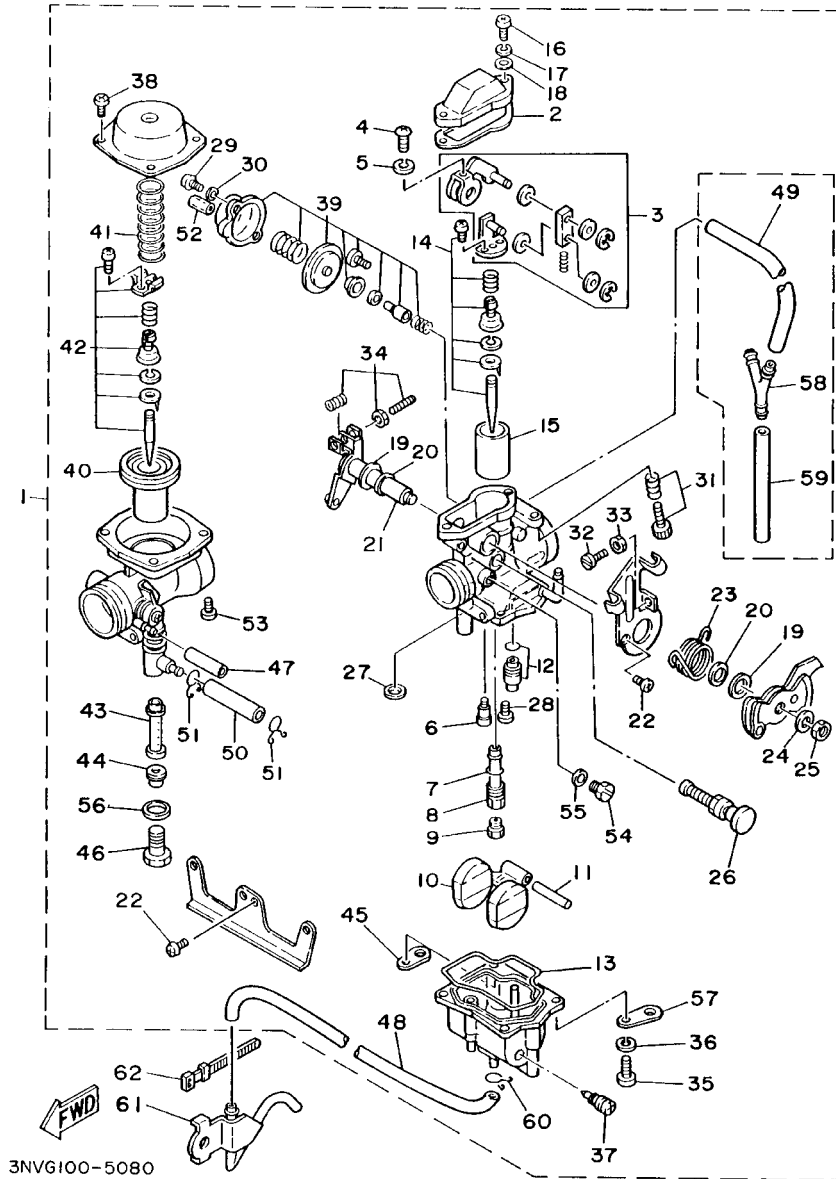

REF. NO.	PART NO.	DESCRIPTION	3NVY	5LJ1	5LJ2	4FC9	REMARKS
25	5Y1-14358-00	.NUT	1	1	1		
26	15A-14371-01	.PLUNGER, STARTER	1	1	1		
27	5Y1-14536-00	.GASKET	1	1	1		
28	98901-04006	.SCREW, BIND	1	1	1		
29	97801-04010	.SCREW, PAN HEAD	2	2	2		
30	92901-04100	.WASHER, SPRING	2	2	2		
31	3WP-14103-00	.THROTTLE SCREW SET	1	1	1		
32	30X-14216-00	.SCREW	1	1	1		
33	30X-14358-00	.NUT	1	1	1		
34	30X-1490K-00	.STOP SCREW SET	1	1	1		
35	97801-04012	.SCREW, PAN HEAD	4	4	4		
36	92901-04100	.WASHER, SPRING	4	4	4		
37	14T-14323-00	.SCREW, AIR ADJUSTING	1	1	1		
38	98501-04008	.SCREW, PAN HEAD	4	4	4		
39	5Y1-1490A-00	.DIAPHRAGM SET, 1	1	1	1		
40	30X-14340-01	.VALVE ASSY	1	1	1		
41	30X-14286-00	.SPRING	1	1	1		
42	57T-1490J-00	.NEEDLE SET	1	1	1		
	56R-1490J-00	.NEEDLE SET		1	1		
43	30X-14355-00	.NOZZLE, MAIN 2	1	1	1		
44	30X-14343-53	.JET, MAIN (#106)	1	1	1		
45	5Y1-14146-00	.PLATE	1	1	1		
46	7KF-14162-00	.BOLT, HOLDING	1	1	1		
47	5Y1-14349-00	.PIPE	1	1	1		
48	5Y1-14396-00	.PIPE	1	1	1		
	56R-14396-00	.PIPE		1	1		
49	34K-14197-00	.PIPE	2	2	2		

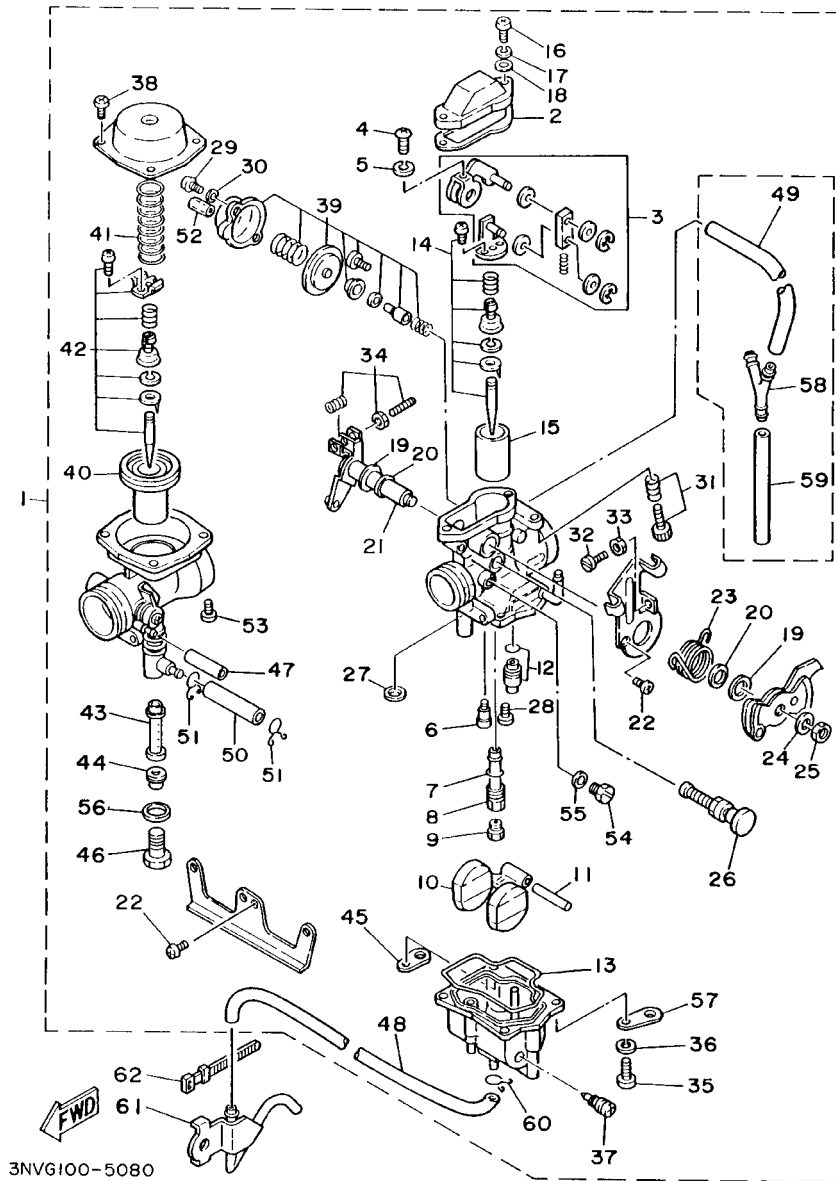
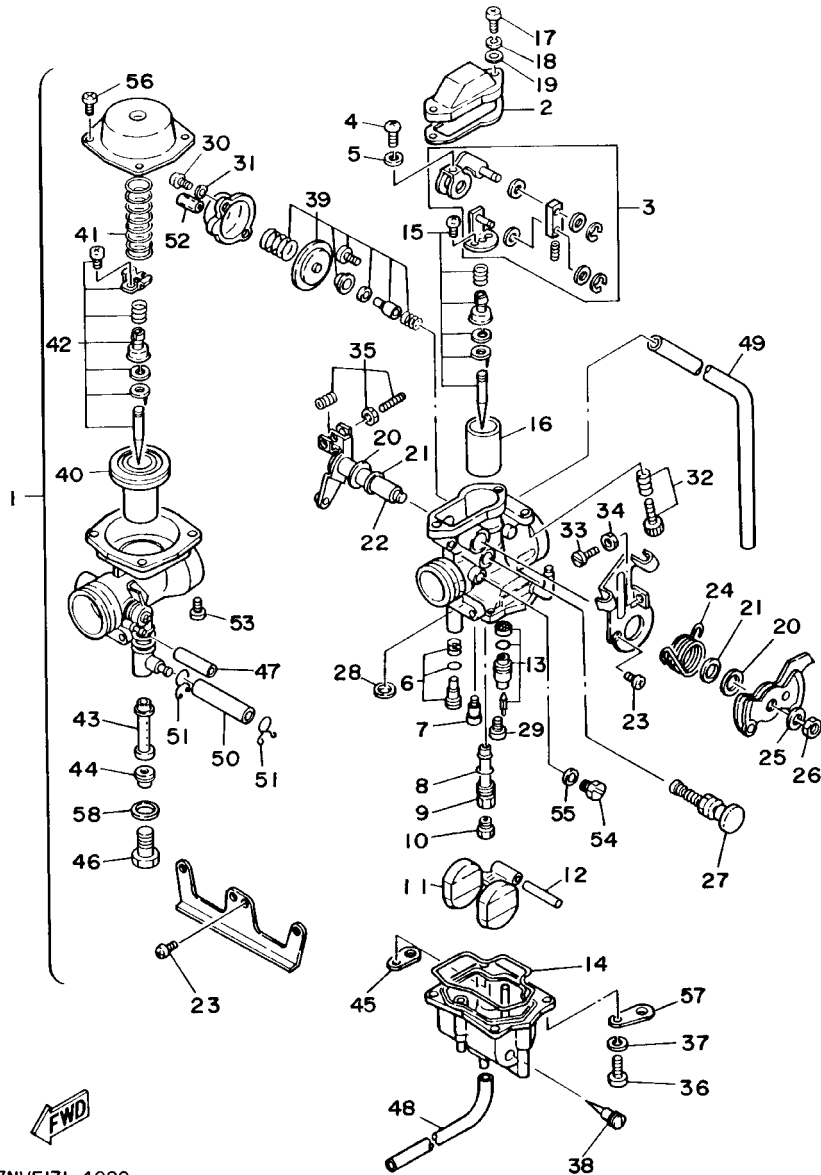

FIG. 8 CARBURETOR

REF. NO.	PART NO.	DESCRIPTION	3NVY	5LJ1	5LJ2	4FC9	REMARKS
49	56R-14197-00	.PIPE		2			
50	30X-14148-00	.PIPE	1	1	1		
51	5Y1-14159-00	.CLIP	2	2	2		
52	30X-14149-00	.PIPE	1	1	1		
53	98501-04010	.SCREW, PAN HEAD	2	2	2		
54	5H0-14991-00	.SCREW	1	1	1		
55	5H0-14126-00	.GASKET	1	1	1		
56	7KF-14227-00	.WASHER	1	1	1		
57	42U-14197-00	.STAY	1		1		
	42U-14146-00	.PLATE		1			
58	90413-05008	.WAY 3		1			
59	56R-14196-00	.PIPE		1			
60	5Y1-14137-00	.CLIP		1			
61	56R-14193-00	PIPE		1			
62	437-83936-01	BAND, SWITCH CORD		1			

FIG. 9 CARBURETOR 2



3NVF171-4080

REF. NO.	PART NO.	DESCRIPTION	3NVY	5LJ1	5LJ2	4FC9	REMARKS
1	55V-14301-05	CARBURETOR ASSY 1				1	
2	30X-14198-00	.GASKET				1	
3	30X-14203-00	.CABLE CONNECTOR SET				1	
4	98580-04015	.SCREW, PAN HEAD				1	
5	92990-04100	.WASHER, SPRING				1	
6	30X-14105-00	.PILOT SCREW SET				1	
7	30X-14342-21	.JET, PILOT (# 42)				1	
8	360-24512-00	.GASKET				2	
9	51Y-14341-00	.NOZZLE, MAIN				1	
10	288-14343-60	.JET, MAIN (#120)				1	
11	5Y1-14385-00	.FLOAT				1	
12	689-14386-00	.PIN, FLOAT				1	
13	1JK-14107-01	.NEEDLE VALVE SET				1	
14	30X-14384-00	.GASKET, FLOAT CHAMBER				1	
15	51Y-1490J-10	.NEEDLE SET				1	
16	30X-14312-35	.VALVE, THROTTLE 1				1	
17	98501-04016	.SCREW, PAN HEAD				2	
18	92901-04100	.WASHER, SPRING				2	
19	92901-04600	.WASHER, PLATE				2	
20	5Y1-14357-00	.WASHER, PLAIN				2	
21	5Y1-14572-00	.PLATE, STAY				2	
22	1LN-14930-00	.THROTTLE SHAFT ASSY				1	
23	97801-05010	.SCREW, PAN HEAD				6	
24	30X-14131-00	.SPRING, THROTTLE VALVE				1	
25	5Y1-14356-00	.WASHER, SPRING				1	
26	5Y1-14358-00	.NUT				1	
27	51Y-14371-01	.PLUNGER, STARTER				1	

FIG. 9 CARBURETOR 2

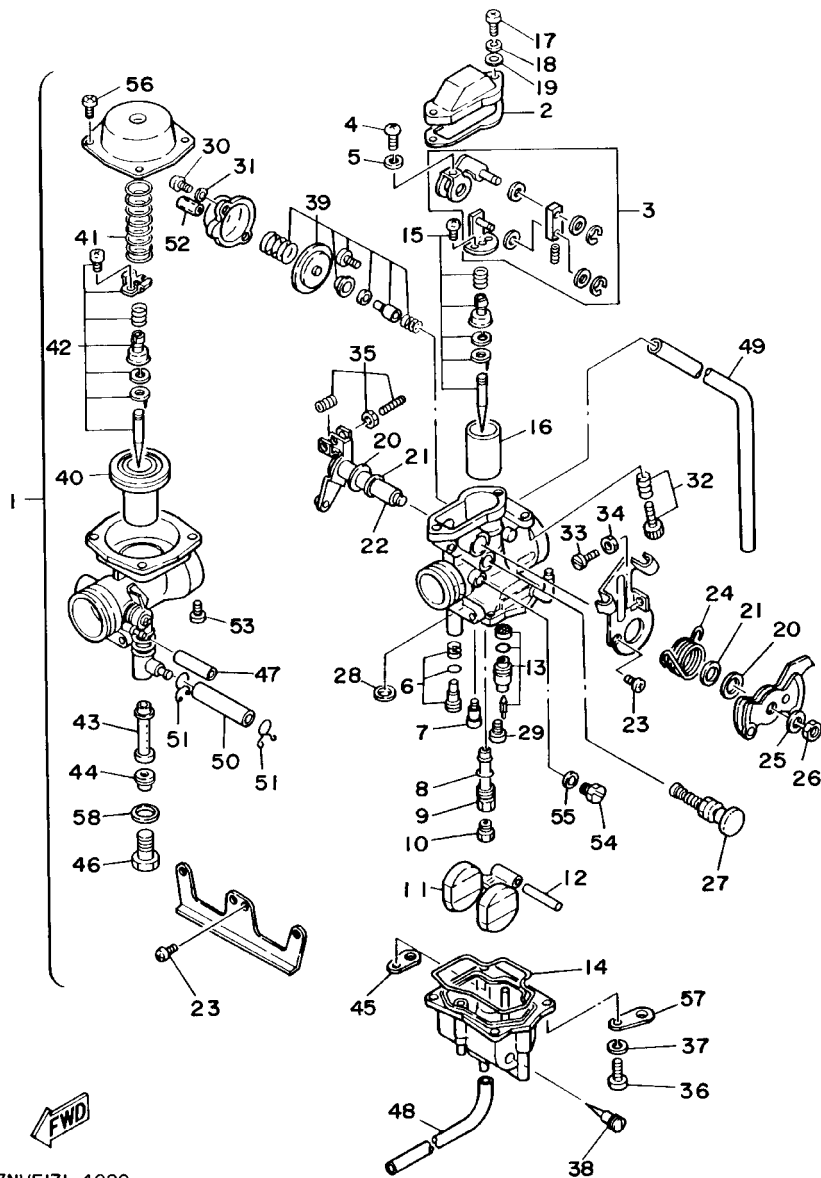

3NVF171-4080

REF. NO.	PART NO.	DESCRIPTION	3NVY	5LJ1	5LJ2	4FC9	REMARKS
28	5Y1-14536-00	.GASKET				1	
29	98901-04006	.SCREW, BIND				1	
30	97801-04010	.SCREW, PAN HEAD				2	
31	92901-04100	.WASHER, SPRING				2	
32	30X-14103-00	.THROTTLE SCREW SET				1	
33	30X-14216-00	.SCREW				1	
34	30X-14358-00	.NUT				1	
35	30X-1490K-00	.STOP SCREW SET				1	
36	97801-04012	.SCREW, PAN HEAD				4	
37	92901-04100	.WASHER, SPRING				4	
38	14T-14323-00	.SCREW, AIR ADJUSTING				1	
39	5Y1-1490A-00	.DIAPHRAGM SET, 1				1	
40	30X-14340-01	.VALVE ASSY				1	
41	30X-14286-00	.SPRING				1	
42	1EU-1490J-00	.NEEDLE SET				1	
43	30X-14355-00	.NOZZLE, MAIN 2				1	
44	30X-14343-51	.JET, MAIN (#102)				1	
45	5Y1-14146-00	.PLATE				1	
46	7KF-14162-00	.BOLT, HOLDING				1	
47	5Y1-14349-00	.PIPE				1	
48	5Y1-14396-00	.PIPE				1	
49	34K-14197-00	.PIPE				2	
50	30X-14148-00	.PIPE				1	
51	5Y1-14159-00	.CLIP				2	
52	30X-14149-00	.PIPE				1	
53	98501-04010	.SCREW, PAN HEAD				2	
54	5H0-14991-00	.SCREW				1	

FIG. 9 CARBURETOR 2

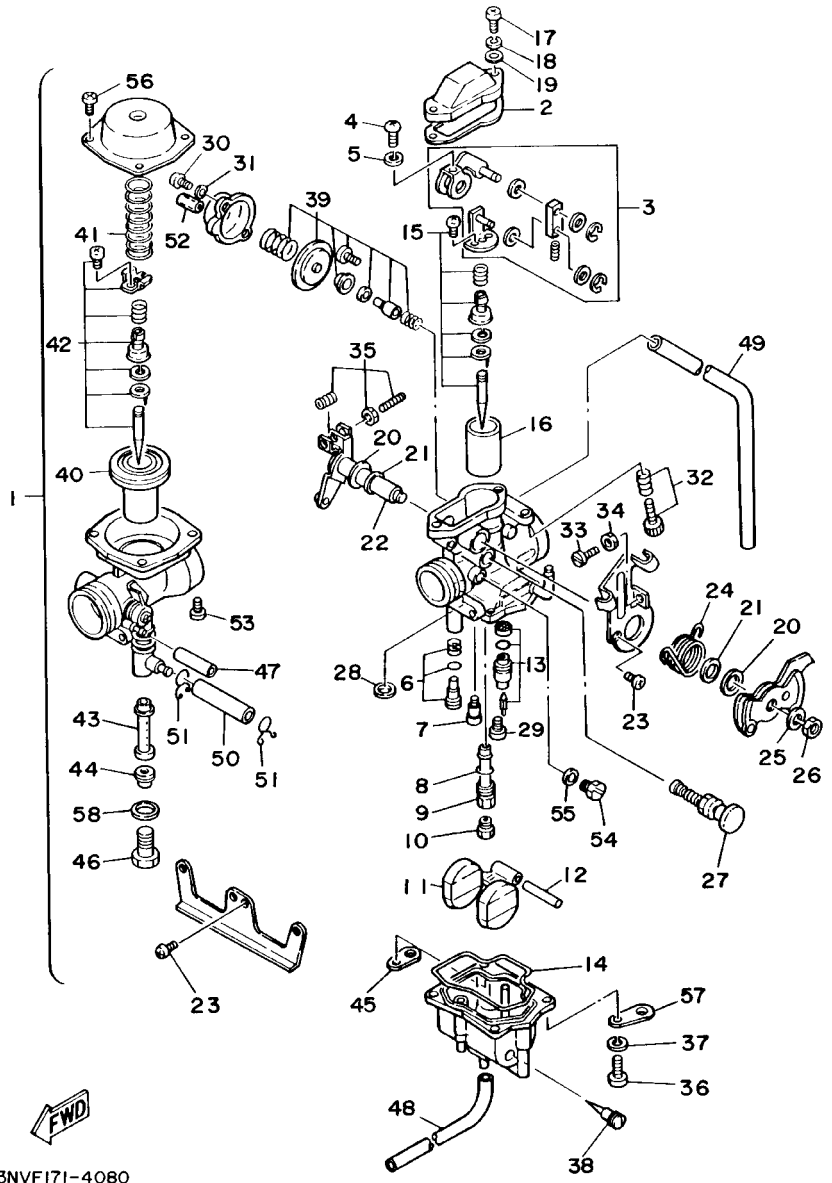

3NVF171-4080

REF. NO.	PART NO.	DESCRIPTION	3NVY	5LJ1	5LJ2	4FC9	REMARKS
55	5H0-14126-00	.GASKET				1	
56	98501-04008	.SCREW, PAN HEAD				4	
57	42U-14146-00	.PLATE				1	
58	7KF-14227-00	.WASHER				1	

FIG. 10 EXHAUST

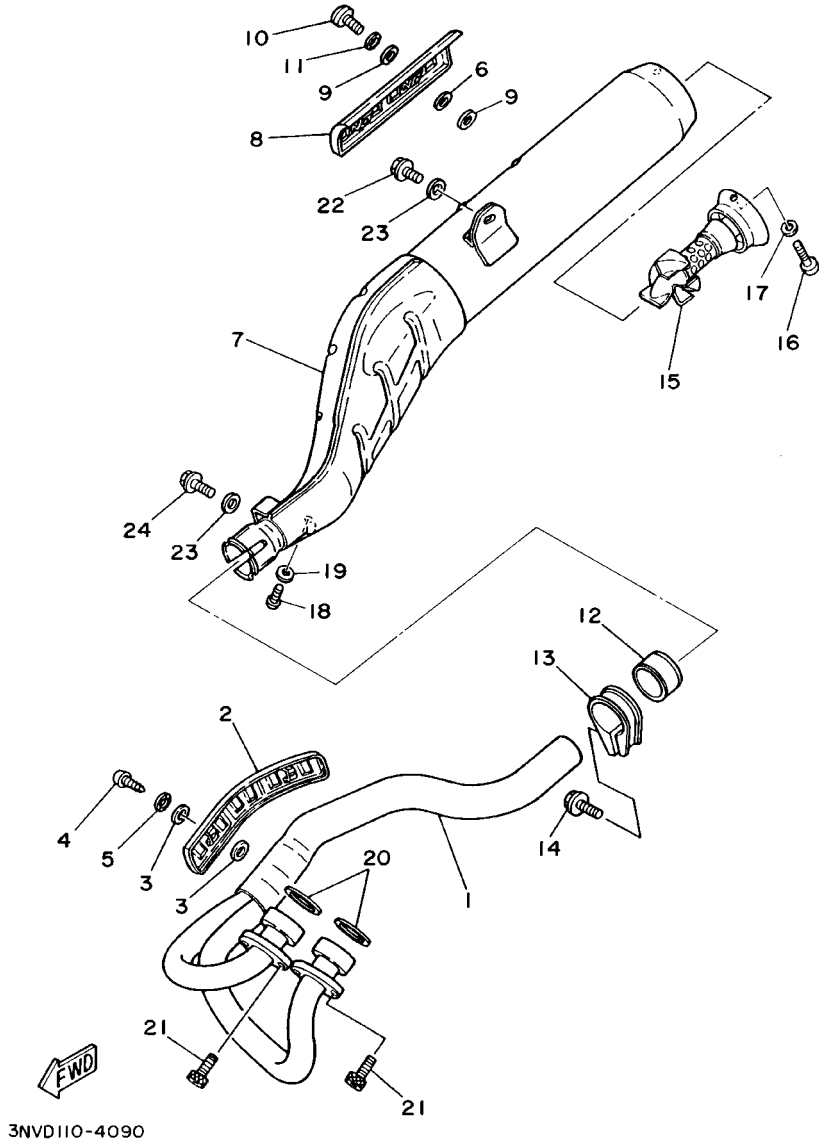

REF. NO.	PART NO.	DESCRIPTION	3NVY	5LJ1	5LJ2	4FC9	REMARKS
1	57R-14611-00	PIPE, EXHAUST 1	1	1	1	1	
2	55V-14628-00	PROTECTOR, EXHAUST PIPE	1	1	1	1	
3	4BD-14766-00	WASHER, PROTECTOR	4	4	4	4	
4	90164-06017	SCREW, TAPPING	2	2	2	2	
5	90206-06090	WASHER, WAVE	2	2	2	2	
6	92907-06600	WASHER, PLATE	2	2	2	2	
7	2GK-14711-01	MUFFLER 1	1	1	1		
	55V-14711-02	MUFFLER 1				1	
8	55V-14728-00	PROTECTOR, MUFFLER 2	1	1	1	1	
9	4BD-14766-00	WASHER, PROTECTOR	4	4	4	4	
10	98907-06010	SCREW, BIND	2	2	2	2	
11	90206-06090	WASHER, WAVE	2	2	2	2	
12	4EL-14714-00	GASKET, MUFFLER	1	1	1	1	
13	30X-14715-00	BAND, MUFFLER	1	1	1	1	
14	95027-08040	BOLT, FLANGE	1	1	1	1	
15	42U-14752-00	PIPE, OUTLET	1	1	1		
16	98507-06010	SCREW, PAN HEAD	1	1	1		
17	92907-06600	WASHER, PLATE	1	1	1		
18	95807-06008	BOLT, FLANGE	1	1	1		
19	92907-06600	WASHER, PLATE	1	1	1		
20	4BR-14613-00	GASKET, EXHAUST PIPE	2	2	2	2	
21	91317-06025	BOLT	4	4	4	4	
22	95817-08014	BOLT, FLANGE	1	1	1	1	
23	90201-08326	WASHER, PLATE	2	2	2	2	
24	95817-08020	BOLT, FLANGE	1	1	1	1	

FIG. 11 CRANKCASE

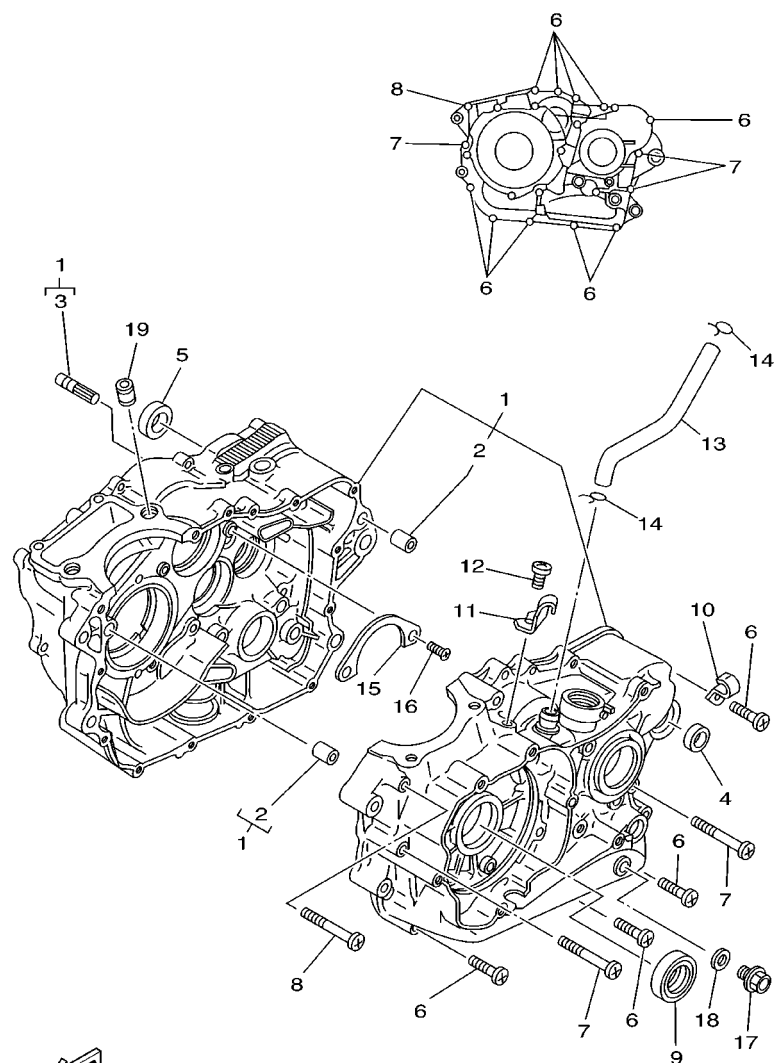

3NVS100-8110

REF. NO.	PART NO.	DESCRIPTION	3NVY	5LJ1	5LJ2	4FC9	REMARKS
1	55V-15100-03	CRANKCASE ASSY	1	1	1	1	
2	99530-12016	.PIN, DOWEL	2	2	2	2	
3	55V-15668-00	.STOPPER	1	1	1	1	
4	90387-17783	COLLAR	1	1	1	1	
5	90387-172J0	COLLAR	1	1	1	1	
6	98507-06030	SCREW, PAN HEAD	10	10	10	10	
7	98507-06060	SCREW, PAN HEAD	3	3	3	3	
8	98507-06070	SCREW, PAN HEAD	1	1	1	1	
9	93102-25305	OIL SEAL	1	1	1	1	
10	90465-08277	CLAMP	1	1	1	1	
11	30X-15441-00	HOLDER, CLUTCH CABLE	1	1	1	1	
12	98507-06016	SCREW, PAN HEAD	1	1	1	1	
13	30X-11166-00	PIPE, BREATHER 1	1	1	1	1	
	56R-11166-00	PIPE, BREATHER 1		1			
14	90467-14015	CLIP	2	2	2	2	
15	30X-15383-00	PLATE, BEARING COVER	1	1	1	1	
16	98707-06016	SCREW, FLAT HEAD	2	2	2	2	
17	90340-14132	PLUG, STRAIGHT SCREW	1	1	1	1	
18	214-11198-01	GASKET	1	1	1	1	
19	99530-14016	PIN, DOWEL	2	2	2	2	

FIG. 12 CRANKCASE COVER 1

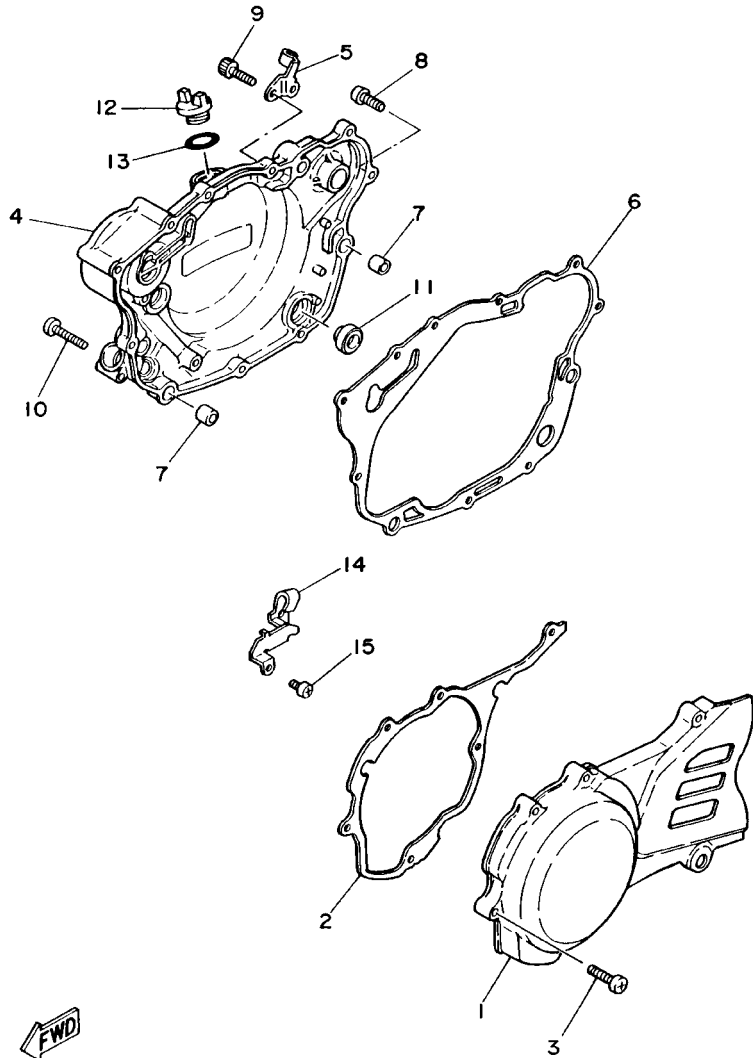

REF. NO.	PART NO.	DESCRIPTION	3NVY	5LJ1	5LJ2	4FC9	REMARKS
1	3DC-15411-00	COVER, CRANKCASE 1	1	1	1	1	
2	4EL-15451-00	GASKET, CRANKCASE COVER 1	1	1	1	1	
3	98507-06030	SCREW, PAN HEAD	6	6	6	6	
4	3GJ-15421-00	COVER, CRANKCASE 2	1	1	1	1	
5	30X-15378-00	HOLDER	1	1	1	1	
6	4EL-15461-02	GASKET, CRANKCASE COVER 2	1	1	1	1	
7	99530-12016	PIN, DOWEL	2	2	2	2	
8	91317-06025	BOLT	2	2	2	2	
9	91317-06030	BOLT	5	5	5	5	
10	91317-06040	BOLT	2	2	2	2	
11	3Y1-15361-00	GAUGE, LEVEL	1	1	1	1	
12	3Y1-15363-00	PLUG, OIL	1	1	1	1	
13	93210-19123	O-RING	1	1	1	1	
14	90462-08062	CLAMP	1	1	1	1	
15	98507-06012	SCREW, PAN HEAD	1	1	1	1	

 55V300-8110

FIG. 13 STARTER

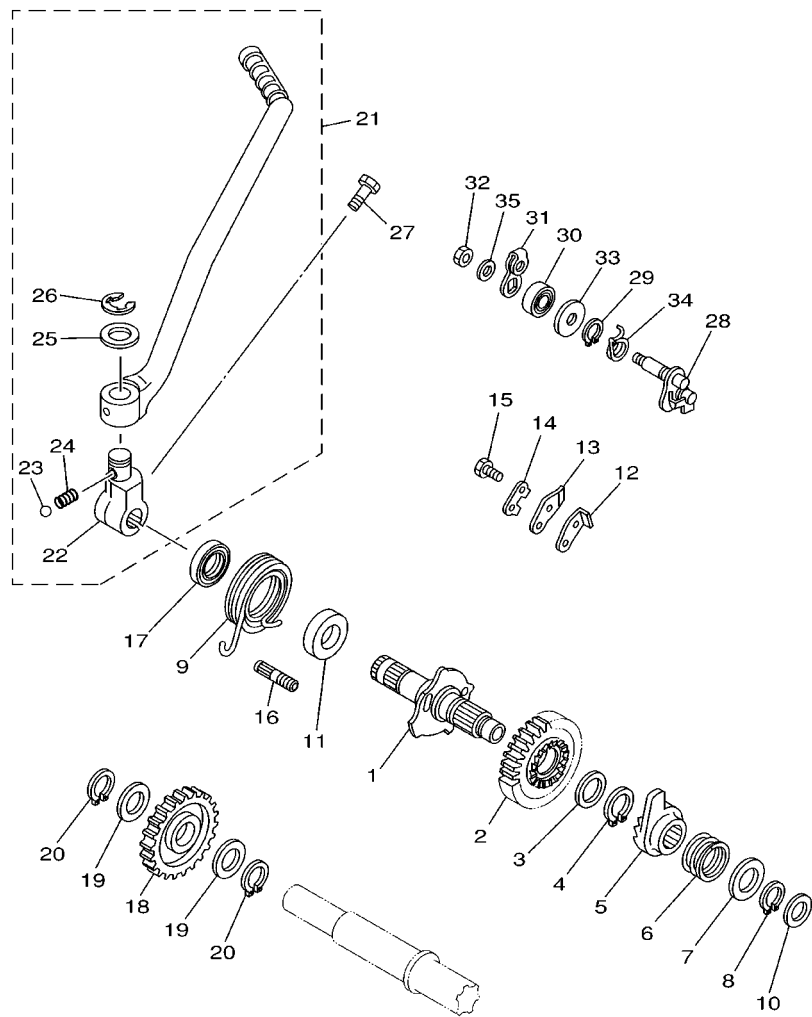

3NVY100-0130

REF. NO.	PART NO.	DESCRIPTION	3NVY	5LJ1	5LJ2	4FC9	REMARKS
1	30X-15660-01	KICK AXLE ASSY	1	1	1	1	
2	30X-15641-01	GEAR, KICK	1	1	1	1	
3	90201-20685	WASHER, PLATE (0.5T)	1	1	1	1	
4	93410-20038	CIRCLIP	1	1	1	1	
5	3Y1-15671-00	WHEEL, RATCHET	1	1	1	1	
6	90501-16107	SPRING, COMPRESSION	1	1	1	1	
7	90201-155K6	WASHER, PLATE	1	1	1	1	
8	99009-15400	CIRCLIP	1	1	1	1	
9	90508-324B5	SPRING, TORSION	1	1	1	1	
10	90201-15701	WASHER, PLATE (1.0T)	1	1	1	1	
11	90560-17239	SPACER	1	1	1	1	
12	2K7-15668-00	STOPPER	1	1	1	1	
13	214-15674-00	GUIDE, RATCHET WHEEL	1	1	1	1	
14	214-15686-00	WASHER, LOCK	1	1	1	1	
15	97027-06016	BOLT	2	2	2	2	
16	55V-15668-00	STOPPER	1	1	1	1	
17	93102-17263	OIL SEAL	1	1	1	1	
18	30X-15651-01	GEAR, KICK IDLE (27T)	1	1	1	1	
19	90201-177G4	WASHER, PLATE	2	2	2	2	
20	99009-17400	CIRCLIP	2	2	2	2	
21	30X-15620-01	KICK CRANK ASSY	1	1	1	1	
22	30X-15621-01	.BOSS, KICK CRANK	1	1	1	1	
23	93507-32009	.BALL	1	1	1	1	
24	90501-12081	.SPRING, COMPRESSION	1	1	1	1	
25	90201-153A1	.WASHER, PLATE	1	1	1	1	
26	99001-10600	.CIRCLIP	1	1	1	1	
27	97017-08030	BOLT	1	1	1	1	

FIG. 13 STARTER

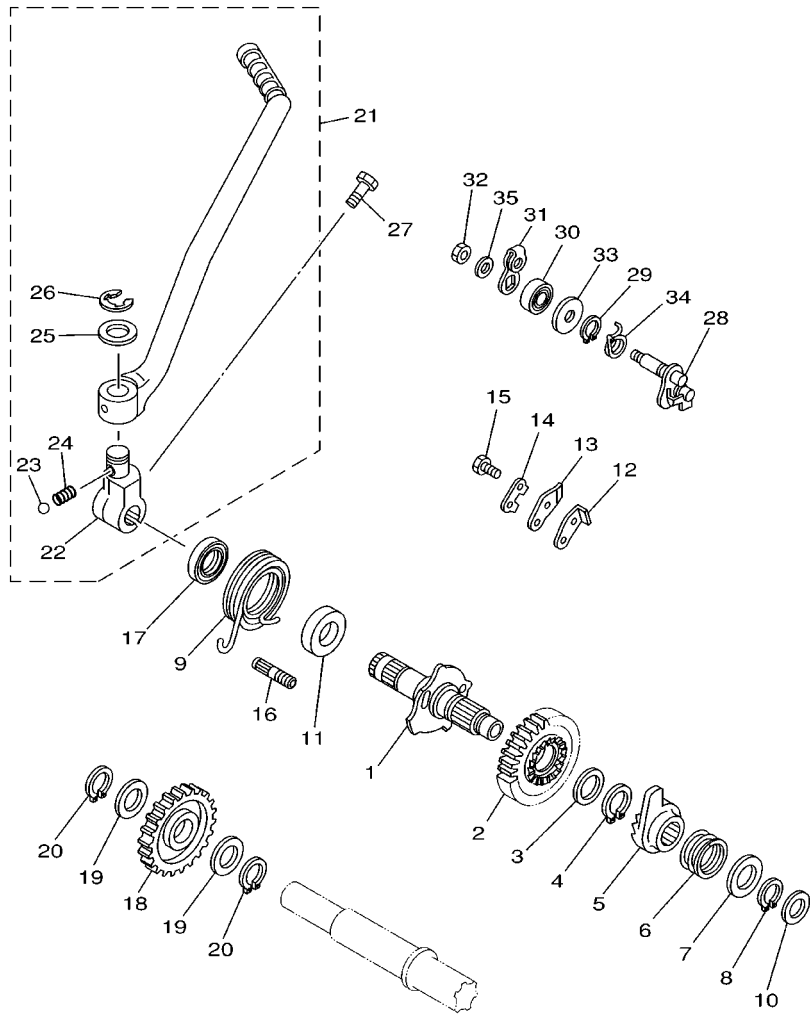

3NVY100-0130

REF. NO.	PART NO.	DESCRIPTION	3NVY	5LJ1	5LJ2	4FC9	REMARKS
28	30X-1561A-00	DECOMP. LEVER ASSY	1	1	1	1	
29	99009-10400	CIRCLIP	1	1	1	1	
30	93102-10207	OIL SEAL (SD 10-21-5 HS)	1	1	1	1	
31	30X-1561G-00	LEVER, CABLE	1	1	1	1	
32	95307-06800	NUT	1	1	1	1	
33	90201-10614	WASHER, PLATE	1	1	1	1	
34	90508-14630	SPRING, TORSION	1	1	1	1	
35	92907-06600	WASHER, PLATE	1	1	1	1	

FIG. 14 CLUTCH

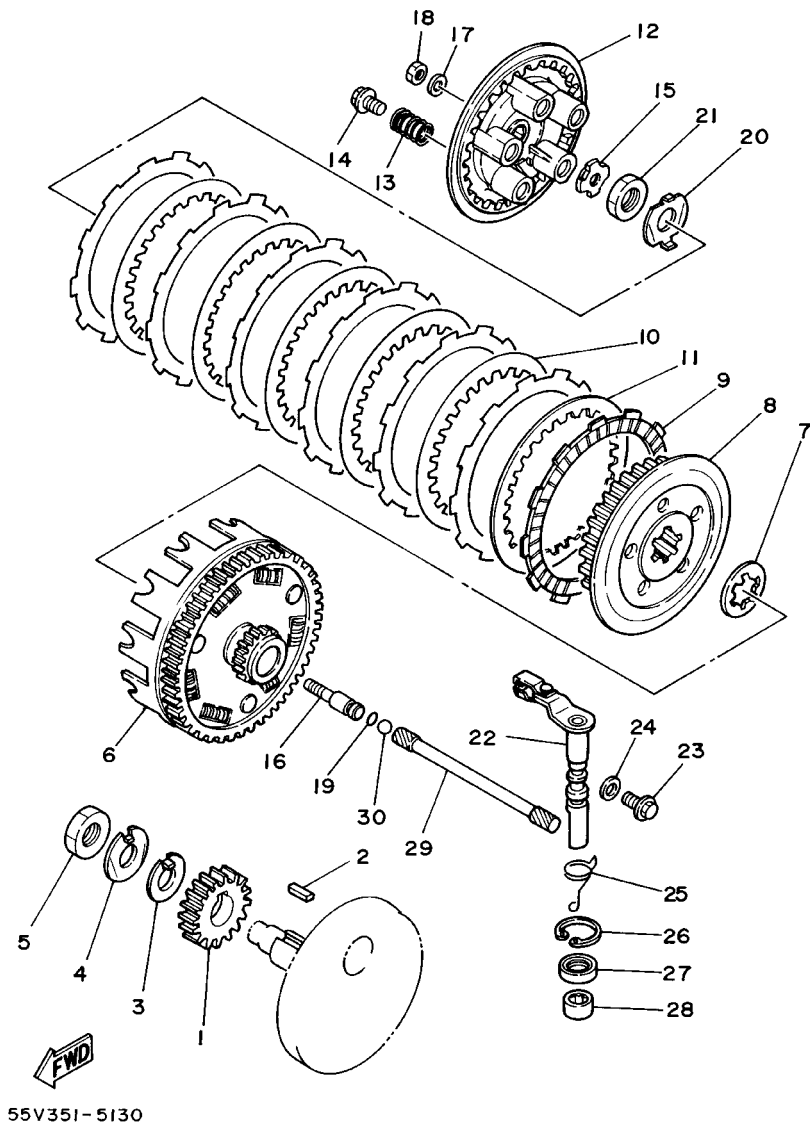

REF. NO.	PART NO.	DESCRIPTION	3NVY	5LJ1	5LJ2	4FC9	REMARKS
1	30X-16111-00	GEAR, PRIMARY DRIVE (23T)	1	1	1	1	
2	90282-07057	KEY, STRAIGHT	1	1	1	1	
3	90215-16156	WASHER, LOCK	1	1	1	1	
4	90215-16222	WASHER, LOCK	1	1	1	1	
5	90170-16343	NUT	1	1	1	1	
6	55V-16150-00	PRIMARY DRIVEN GEAR COMP.	1	1	1	1	
7	30X-16154-00	PLATE, THRUST 1	1	1	1	1	
8	55V-16371-00	BOSS, CLUTCH	1	1	1	1	
9	5Y1-16331-01	PLATE, FRICTION 2	7	7	7	7	
10	168-16325-00	PLATE, CLUTCH 2	5	5	5	5	
11	3J2-16324-00	PLATE, CLUTCH 1	1	1	1	1	
12	5Y1-16351-00	PLATE, PRESSURE 1	1	1	1	1	
13	90501-23391	SPRING, COMPRESSION	5	5	5	5	
14	90159-06010	SCREW, WITH WASHER	5	5	5	5	
15	1W1-16358-01	PLATE, PUSH	1	1	1	1	
16	55V-16356-00	ROD, PUSH 1	1	1	1	1	
17	92907-06200	WASHER	1	1	1	1	
18	95307-06600	NUT	1	1	1	1	
19	93210-06422	O-RING	1	1	1	1	
20	90215-16289	WASHER, LOCK	1	1	1	1	
21	90170-16326	NUT	1	1	1	1	
22	55V-16380-00	PUSH LEVER ASSY	1	1	1	1	
23	90149-08067	SCREW	1	1	1	1	
24	90430-08119	GASKET	1	1	1	1	
25	90508-14433	SPRING, TORSION	1	1	1	1	
26	93420-28055	CIRCLIP	1	1	1	1	
27	93102-14209	OIL SEAL	1	1	1	1	

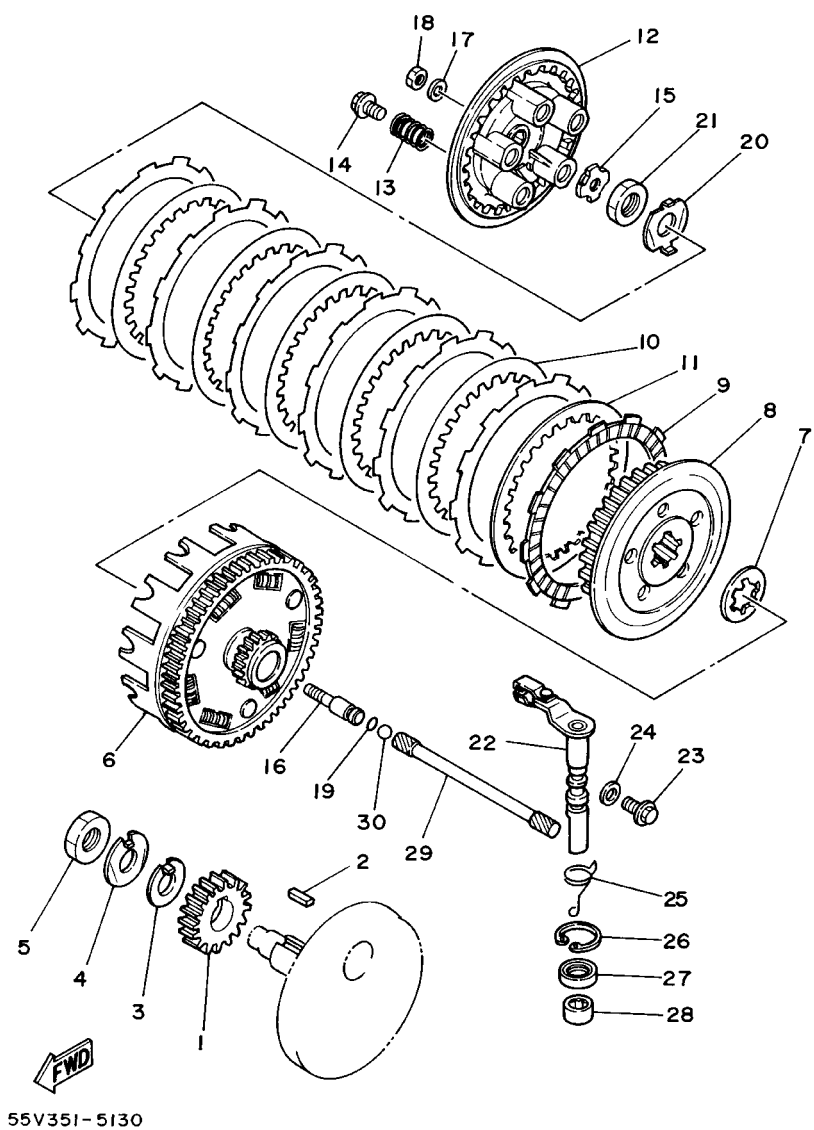
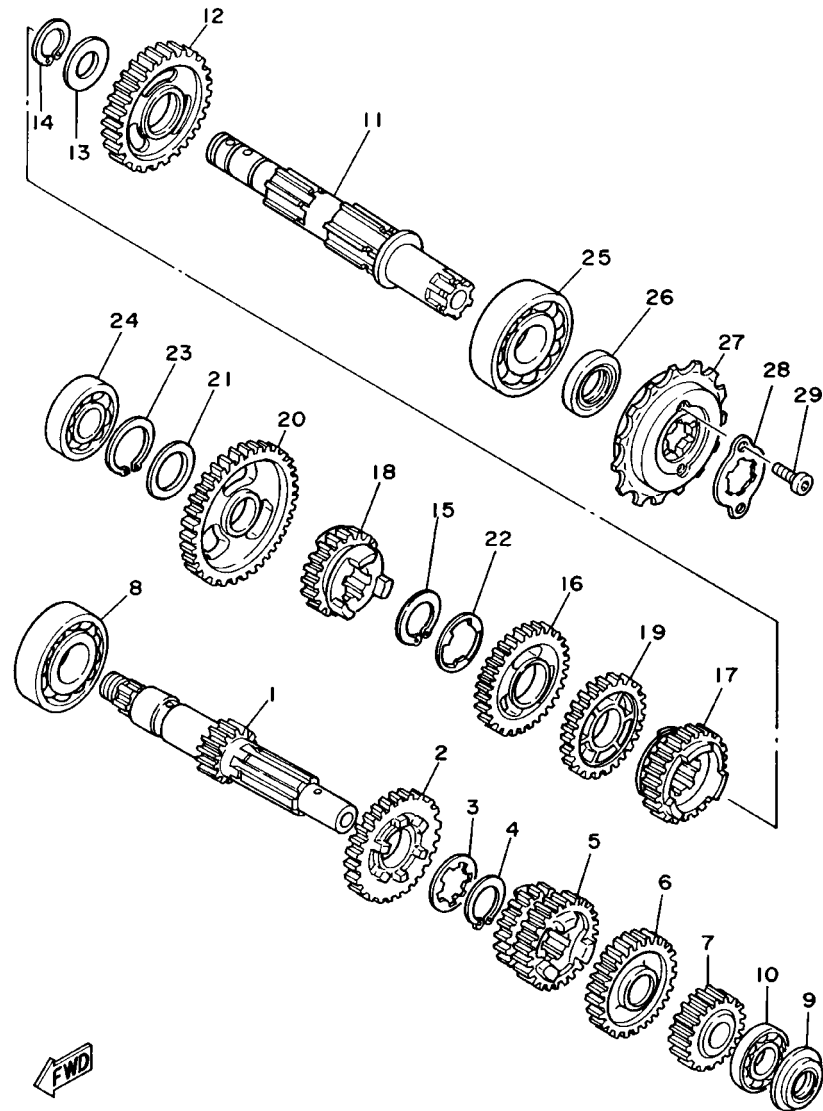

FIG. 14 CLUTCH

REF. NO.	PART NO.	DESCRIPTION	3NVY	5LJ1	5LJ2	4FC9	REMARKS
28	93315-31428	BEARING	1	1	1	1	
29	30X-16357-00	ROD, PUSH 2	1	1	1	1	
30	93511-32017	BALL	1	1	1	1	
<hr/>							
<hr/>							
<hr/>							
<hr/>							
<hr/>							
<hr/>							
<hr/>							
<hr/>							

FIG. 15 TRANSMISSION



52E010-4140



REF. NO.	PART NO.	DESCRIPTION	3NVJ	5LJ1	5LJ2	4FC9	REMARKS
1	51Y-17411-00	AXLE, MAIN (15T)	1	1	1	1	
2	55V-17161-00	GEAR, 6TH PINION (29T)	1	1	1	1	
3	90209-18208	WASHER	1	1	1	1	
4	93410-22039	CIRCLIP	1	1	1	1	
5	55V-17131-00	GEAR, 3RD PINION (25T)	1	1	1	1	
6	55V-17151-02	GEAR, 5TH PINION (27T)	1	1	1	1	
7	51Y-17121-00	GEAR, 2ND PINION (16T)	1	1	1	1	
8	93306-20427	BEARING (62/22-9-C3)	1	1	1	1	
9	93101-17093	OIL SEAL	1	1	1	1	
10	93306-00315	BEARING (6003SH2C4)	1	1	1	1	
11	55V-17402-00	DRIVE AXLE ASSY	1	1	1	1	
12	51Y-17221-00	GEAR, 2ND WHEEL (29T)	1	1	1	1	
13	90209-23241	WASHER	1	1	1	1	
14	93410-26067	CIRCLIP	1	1	1	1	
15	93410-22039	CIRCLIP	1	1	1	1	
16	55V-17231-00	GEAR, 3RD WHEEL (30T)	1	1	1	1	
17	55V-17251-00	GEAR, 5TH WHEEL (24T)	1	1	1	1	
18	55V-17261-01	GEAR, 6TH WHEEL (22T)	1	1	1	1	
19	55V-17241-00	GEAR, 4TH WHEEL (27T)	1	1	1	1	
20	51Y-17211-00	GEAR, 1ST WHEEL (37T)	1	1	1	1	
21	90201-177G4	WASHER, PLATE	1	1	1	1	
22	90209-18208	WASHER	1	1	1	1	
23	93410-17037	CIRCLIP	1	1	1	1	
24	93306-20332	BEARING	1	1	1	1	
25	93306-20532	BEARING	1	1	1	1	
26	93102-25226	OIL SEAL	1	1	1	1	
27	55V-17460-00	SPROCKET,DRIVE 19T(55V1746190)	1	1	1	1	

FIG. 15 TRANSMISSION

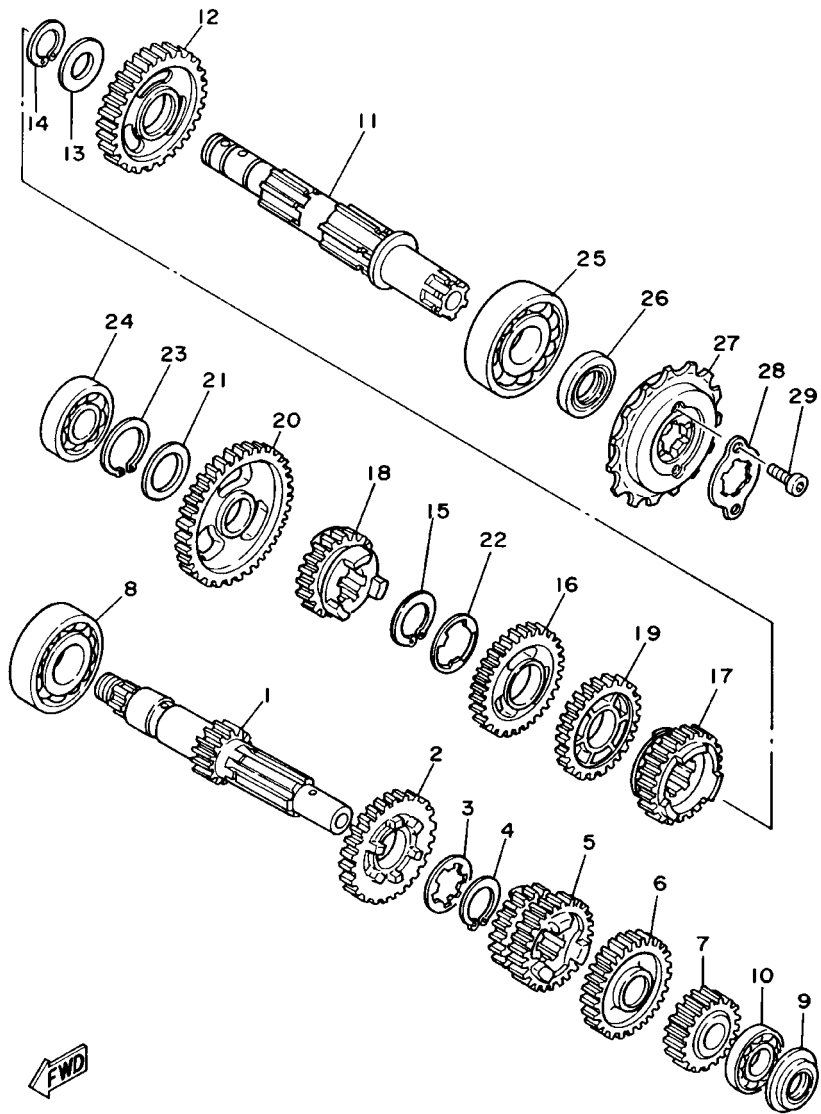

52E010-4140

REF. NO.	PART NO.	DESCRIPTION	3NVY	5LJ1	5LJ2	4FC9	REMARKS
28	3Y1-17456-00	HOLDER, SPROCKET	1	1	1	1	
29	97027-06010	BOLT	2	2	2	2	

FIG. 16 TACHOMETER GEAR

REF. NO.	PART NO.	DESCRIPTION	3NVY	5LJ1	5LJ2	4FC9	REMARKS
1	30X-17861-00	AXLE, DRIVE GEAR	1	1	1	1	
2	30X-17831-00	GEAR, DRIVE (23T)	1	1	1	1	
3	90201-105E8	WASHER, PLATE	2	2	2	2	
4	99009-10400	CIRCLIP	1	1	1	1	
5	30X-17841-01	GEAR, DRIVEN	1	1	1	1	
6	98507-06025	SCREW, PAN HEAD	1	1	1	1	
7	93102-08307	OIL SEAL	1	1	1	1	
8	90201-12163	WASHER, PLATE	1	1	1	1	

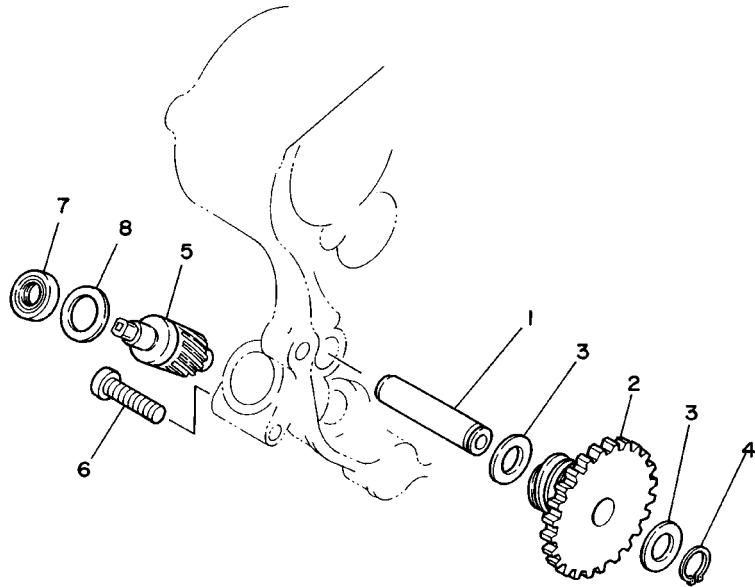

30X010-3150

FIG. 17 SHIFT CAM. FORK

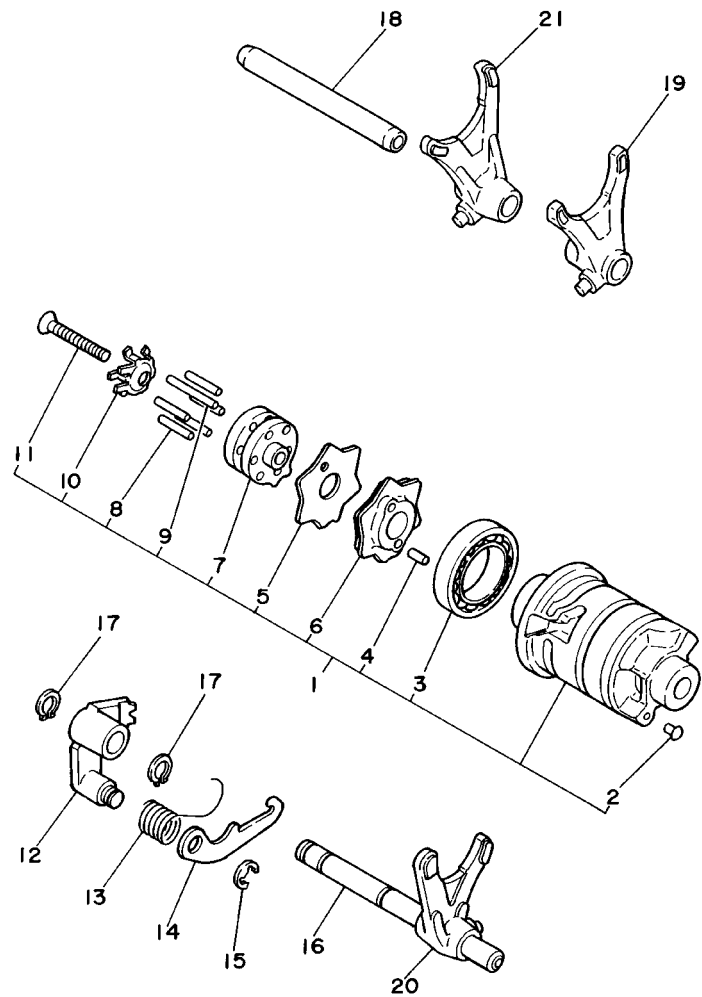

30X010-3160

REF. NO.	PART NO.	DESCRIPTION	3NVY	5LJ1	5LJ2	4FC9	REMARKS
1	30X-18540-00	SHIFT CAM ASSY	1	1	1	1	
2	136-18542-00	.POINT, NEUTRAL	1	1	1	1	
3	93306-90501	.BEARING	1	1	1	1	
4	93604-08071	.PIN, DOWEL	1	1	1	1	
5	30X-18161-00	.GUIDE, PLATE STOPPER	1	1	1	1	
6	30X-18141-00	.PLATE, STOPPER	1	1	1	1	
7	30X-18185-00	.SEGMENT	1	1	1	1	
8	93604-18100	.PIN, DOWEL	5	5	5	5	
9	93604-29151	.PIN, DOWEL	1	1	1	1	
10	30X-18561-02	.PLATE, SIDE 1	1	1	1	1	
11	90151-06013	.SCREW, COUNTERSUNK	1	1	1	1	
12	3Y1-18122-00	LEVER, SHIFT 2	1	1	1	1	
13	90508-12430	SPRING, TORSION	1	1	1	1	
14	2K7-18151-00	LEVER, SHIFT 3	1	1	1	1	
15	99001-07600	CIRCLIP	1	1	1	1	
16	4DN-18531-00	BAR, SHIFT FORK GUIDE 1	1	1	1	1	
17	99009-10400	CIRCLIP	2	2	2	2	
18	4DN-18535-00	BAR, SHIFT FORK GUIDE 2	1	1	1	1	
19	30X-18511-00	FORK, SHIFT 1	1	1	1	1	
20	30X-18512-00	FORK, SHIFT 2	1	1	1	1	
21	30X-18513-00	FORK, SHIFT 3	1	1	1	1	

FIG. 18 SHIFT SHAFT

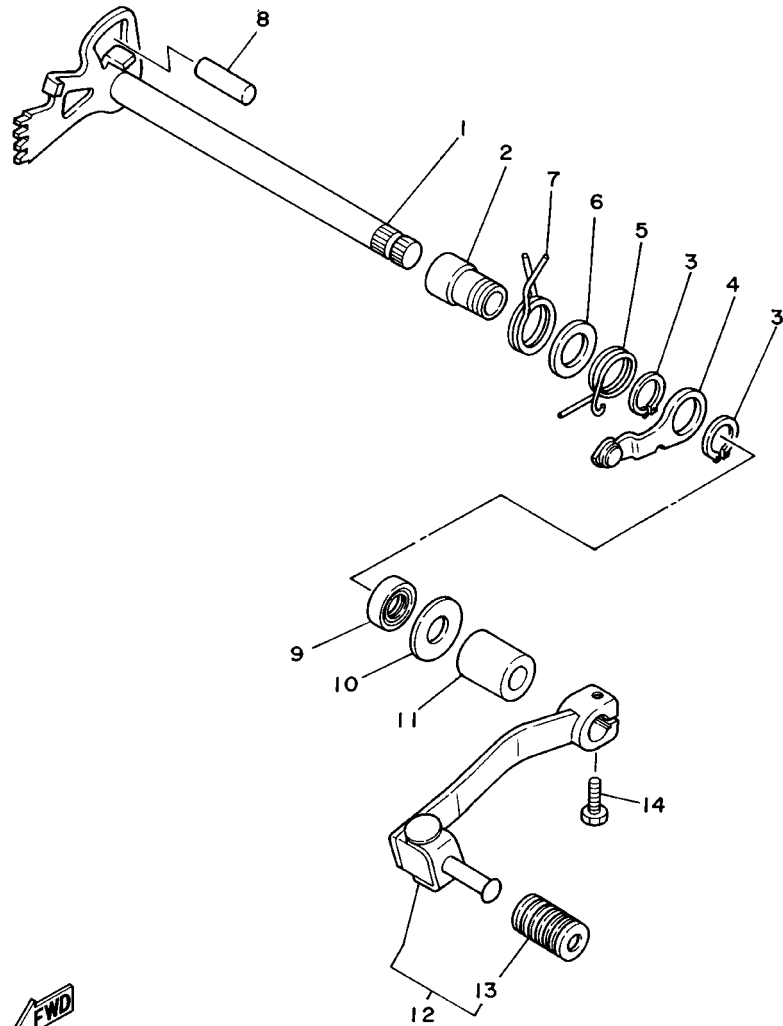

REF. NO.	PART NO.	DESCRIPTION	3NVY	5LJ1	5LJ2	4FC9	REMARKS
1	30X-18101-01	SHIFT SHAFT ASSY	1	1	1	1	
2	90387-12787	COLLAR	1	1	1	1	
3	99009-17400	CIRCLIP	2	2	2	2	
4	3Y1-18140-00	STOPPER LEVER ASSY	1	1	1	1	
5	90508-26434	SPRING, TORSION	1	1	1	1	
6	90201-17255	WASHER, PLATE	1	1	1	1	
7	90508-32374	SPRING, TORSION	1	1	1	1	
8	93608-30152	PIN, DOWEL	1	1	1	1	
9	93102-12106	OIL SEAL (SD 12-22-5 HS)	1	1	1	1	
10	90201-12588	WASHER, PLATE	1	1	1	1	
11	90560-12191	SPACER	1	1	1	1	
12	30X-18110-01	SHIFT PEDAL ASSY	1	1	1	1	
13	1W6-18113-00	.COVER, SHIFT PEDAL	1	1	1	1	
14	97027-06020	BOLT	1	1	1	1	

57R700- 5170

FIG. 19 FRAME

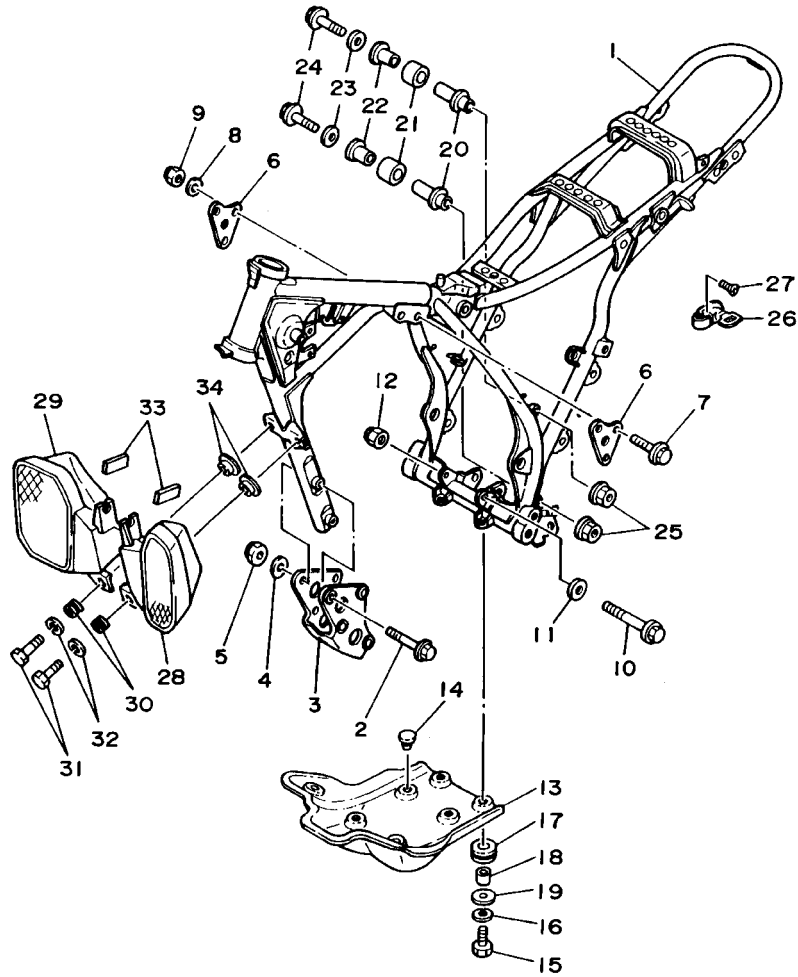

REF. NO.	PART NO.	DESCRIPTION	3NVY	5LJ1	5LJ2	4FC9	REMARKS
1	57T-21110-00-35	FRAME COMP.	1		1		SL
	56R-21110-00-35	FRAME COMP.		1			SL
	3YT-21110-00-35	FRAME COMP.				1	SL
2	95817-08070	BOLT, FLANGE	4	4	4	4	
3	30X-21316-00-35	STAY, ENGINE 3	1	1	1	1	SL
4	90201-08366	WASHER, PLATE	4	4	4	4	
5	90185-08089	NUT, SELF-LOCKING	4	4	4	4	
6	30X-21315-00	STAY, ENGINE 2	2	2	2	2	
7	95817-08060	BOLT, FLANGE	3	3	3	3	
8	90201-08366	WASHER, PLATE	3	3	3	3	
9	90185-08089	NUT, SELF-LOCKING	3	3	3	3	
10	90105-08099	BOLT, WASHER BASED	1	1	1	1	
11	90201-08366	WASHER, PLATE	1	1	1	1	
12	90185-08089	NUT, SELF-LOCKING	1	1	1	1	
13	30X-21471-01	PROTECTOR, ENGINE	1	1	1	1	
14	30X-24768-00	STOPPER	5	5	5	5	
15	97007-06020	BOLT	3	3	3	3	
16	92907-06600	WASHER, PLATE	3	3	3	3	
17	90480-16233	GROMMET	3	3	3	3	
18	90387-07674	COLLAR	3	3	3	3	
19	90201-06071	WASHER, PLATE	3	3	3	3	
20	2K7-2148A-00	SHAFT	2	2	2	2	
21	30X-22178-00	TENSIONER	2	2	2	2	
22	10V-22184-00	BUSH	2	2	2	2	
23	90201-08310	WASHER, PLATE	2	2	2		
	90201-08753	WASHER, PLATE				2	
24	95807-08050	BOLT, FLANGE	2	2	2	2	

FWD
3NVK100-6190

FIG. 19 FRAME

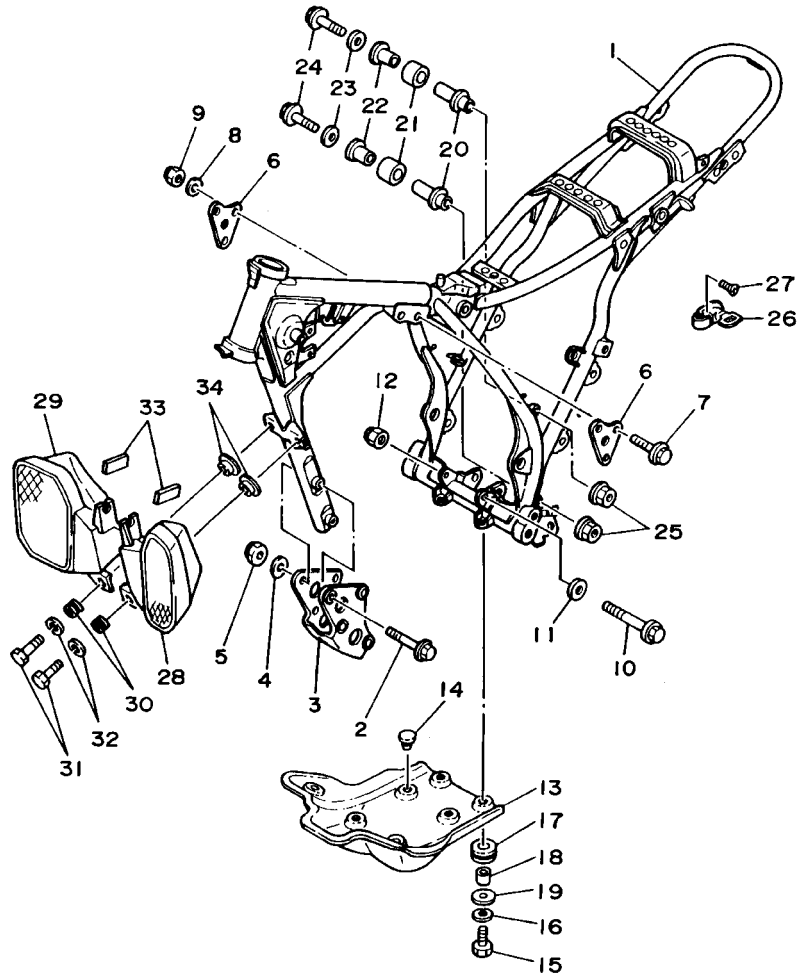

REF. NO.	PART NO.	DESCRIPTION	3NVY	5LJ1	5LJ2	4FC9	REMARKS
25	95607-08100	NUT, U	2	2	2	2	
26	5H0-21308-01	HELMET HANGER ASSY	1	1	1	1	
27	90149-06285	SCREW	1	1	1	1	
28	55V-2137W-50	SCOOP, AIR 1	1	1	1	1	PWS1
29	55V-2137X-50	SCOOP, AIR 2	1	1	1	1	PWS1
<hr/>							
30	90480-12053	GROMMET	2	2	2	2	
31	97007-06016	BOLT	2	2	2	2	
32	92907-06600	WASHER, PLATE	2	2	2	2	
33	30X-2139X-00	DAMPER	2	2	2	2	
34	90209-06187	WASHER	2	2	2	2	
<hr/>							
<hr/>							
<hr/>							
<hr/>							
<hr/>							
<hr/>							
<hr/>							
<hr/>							

3NVK100-6190

FIG. 20 FENDER

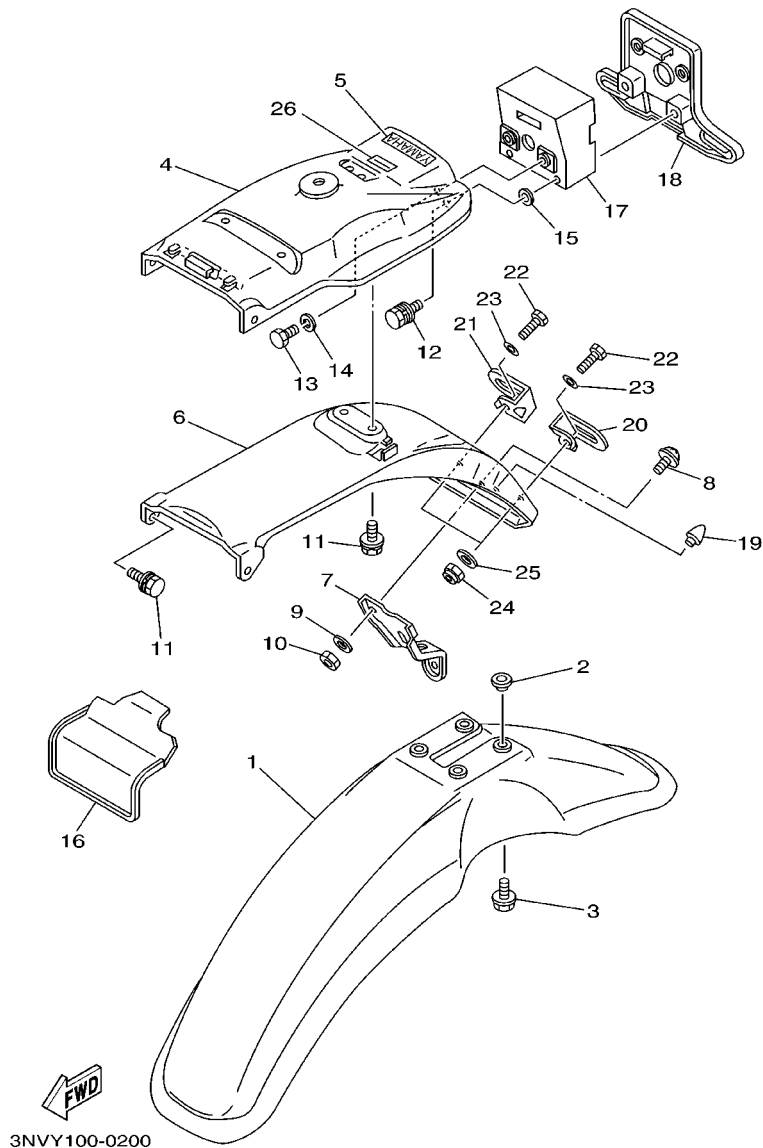

REF. NO.	PART NO.	DESCRIPTION	3NVY	5LJ1	5LJ2	4FC9	REMARKS
1	30X-21511-30	FENDER, FRONT	1	1	1		PWS1
2	90387-06681	COLLAR	4	4	4		
3	90119-06063	BOLT, WITH WASHER	4	4	4		
4	42U-21611-10	FENDER, REAR	1	1	1		PWS1
5	3WF-2153E-70	EMBLEM, YAMAHA	1	1	1		
6	42U-21685-00	BRACKET, LICENSE	1	1	1		
7	42U-21641-00	BRACKET, REFLECTOR	1	1	1		
8	90159-06033	SCREW, WITH WASHER	2	2	2		
9	92907-06100	WASHER, SPRING	2	2	2		
10	95307-06600	NUT	2	2	2		
11	90119-06063	BOLT, WITH WASHER	4	4	4		
12	90119-06063	BOLT, WITH WASHER	2	2	2		
13	97007-06045	BOLT	2	2	2		
14	92907-06600	WASHER, PLATE	2	2	2		
15	90201-06778	WASHER, PLATE	2	2	2		
16	30X-21629-00	GUARD, MUD	1	1	1		
17	21T-2163A-00	COVER, REAR FENDER 1	1	1	1		
18	21T-21685-20	BRACKET, LICENSE	1	1	1		
19	42U-21639-00	DAMPER 2	1	1	1		
20	42U-21688-00	BRACKET, REAR STAY	1	1	1		
21	42U-21689-00	BRACKET, REAR STAY 2	1	1	1		
22	97007-06020	BOLT	2	2	2		
23	92907-06600	WASHER, PLATE	2	2	2		
24	95607-06100	NUT, U	2	2	2		
25	90201-06380	WASHER, PLATE	2	2	2		
26	3MX-24875-A0	LABEL 1	1	1	1		ENGLISH

FIG. 21 FENDER 2

REF. NO.	PART NO.	DESCRIPTION	3NVY	5LJ1	5LJ2	4FC9	REMARKS
1	30X-21511-30	FENDER, FRONT				1	PWS1
2	90387-06681	COLLAR				4	
3	90119-06063	BOLT, WITH WASHER				4	
4	30X-21611-30	FENDER, REAR				1	PWS1
5	3WF-2153E-70	EMBLEM, YAMAHA				1	
6	30X-W2164-00	LICENSE BRACKET				1	
7	30X-21641-01	.BRACKET, REFLECTOR				1	
8	90267-40029	.RIVET, BLIND				2	
9	90201-04018	.WASHER, PLATE				4	
10	90119-06063	BOLT, WITH WASHER				4	
11	90119-06063	BOLT, WITH WASHER				2	
12	90201-06778	WASHER, PLATE				2	
13	95607-06100	NUT, U				2	
14	30X-21629-00	GUARD, MUD				1	
15	98907-06012	SCREW, BIND				3	
16	3HP-21568-00	LABEL, WARNING				1	ENGLISH

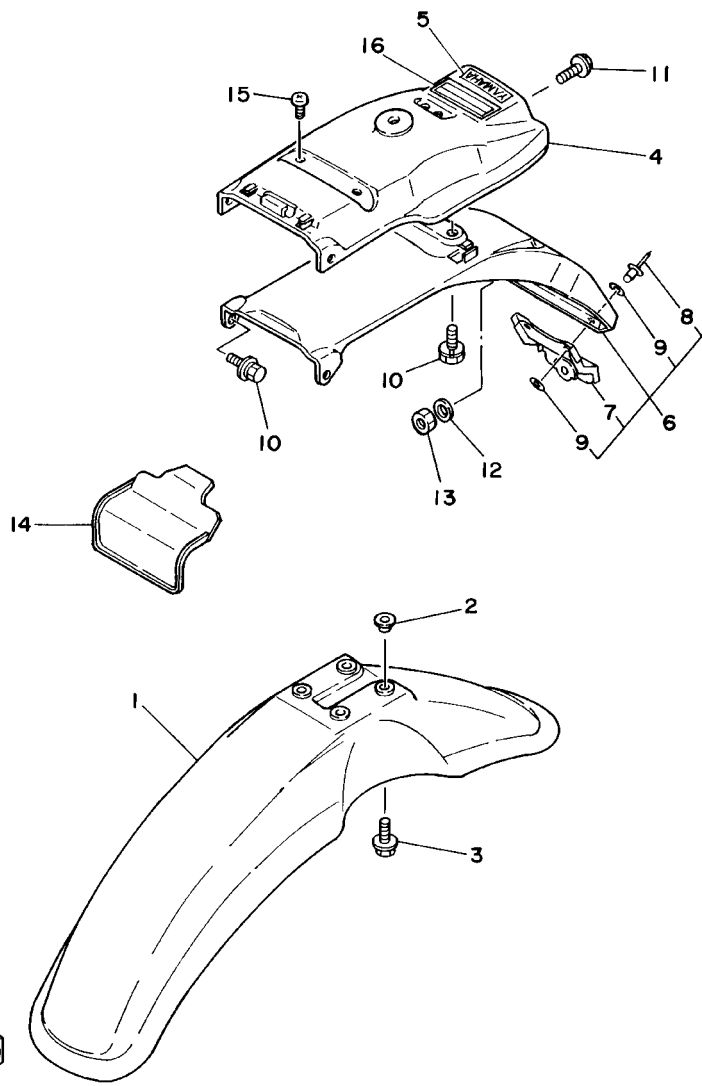

4FC1700-2190

FIG. 22 SIDE COVER

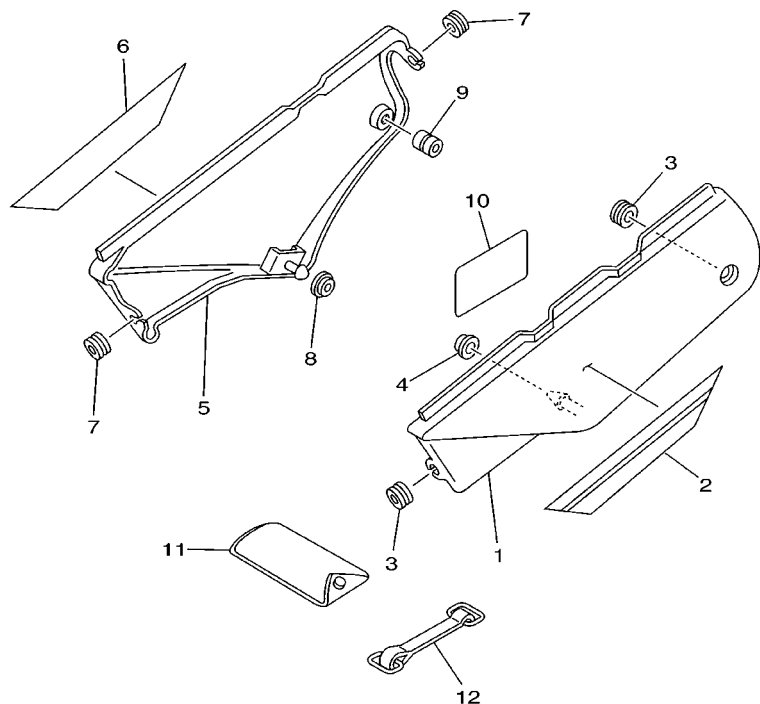

REF. NO.	PART NO.	DESCRIPTION	3NVY	5LJ1	5LJ2	4FC9	REMARKS
1	30X-21711-30-0X	COVER, SIDE 1	1	1	1		PWS1/LGB
2	3NV-2173E-70	GRAPHIC 1	1	1	1		
3	90480-12053	GROMMET	2	2	2		
4	90480-01141	GROMMET	1	1	1		
5	30X-21721-30-0X	COVER, SIDE 2	1	1	1		PWS1/LGB
6	3NV-2173F-70	GRAPHIC 2	1	1	1		
7	90480-12053	GROMMET	2	2	2		
8	90480-01141	GROMMET	1	1	1		
9	22W-24181-00	DAMPER, LOCATING 1	1	1	1		
10	3NV-2179V-B0	PLATE, EPA 1(NON CALIFORNIA)	1				
	3NV-2179R-B0	PLATE, EPA 2(CALIFORNIA)		1			
11	48Y-28100-00	TOOL KIT	1	1	1		
12	116-82131-00	BAND, BATTERY	1	1	1		

3NVY100-0220

D6

FIG. 23 SIDE COVER 2

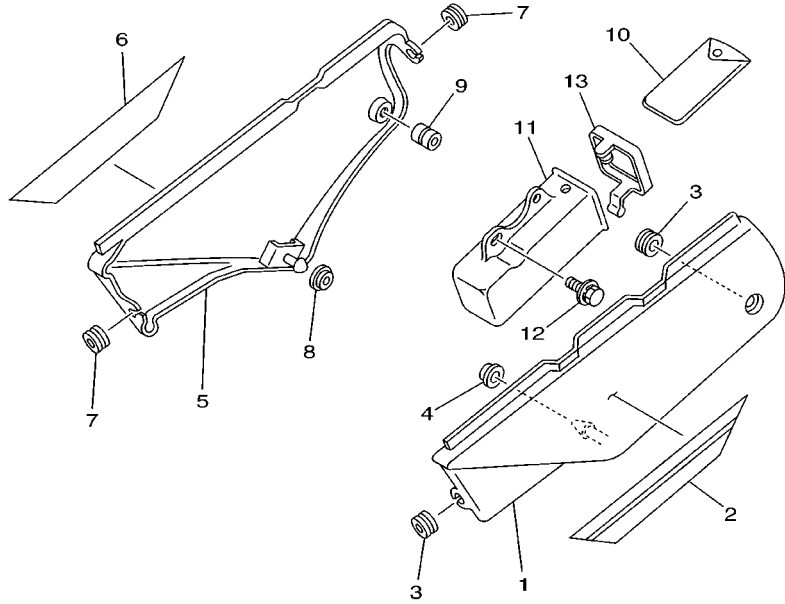

REF. NO.	PART NO.	DESCRIPTION	3NVY	5LJ1	5LJ2	4FC9	REMARKS
1	30X-21711-30-0X	COVER, SIDE 1				1	PWS1/LGB
2	3NV-2173E-70	GRAPHIC 1				1	
3	90480-12053	GROMMET				2	
4	90480-01141	GROMMET				1	
5	30X-21721-30-0X	COVER, SIDE 2				1	PWS1/LGB
6	3NV-2173F-70	GRAPHIC 2				1	
7	90480-12053	GROMMET				2	
8	90480-01141	GROMMET				1	
9	22W-24181-00	DAMPER, LOCATING 1				1	
10	48Y-28100-00	TOOL KIT				1	
11	55V-28173-01	BOX, TOOL				1	
12	90119-06063	BOLT, WITH WASHER				2	
13	55V-28185-00	LID				1	

 3NVY 100-0230

FIG. 24 REAR ARM

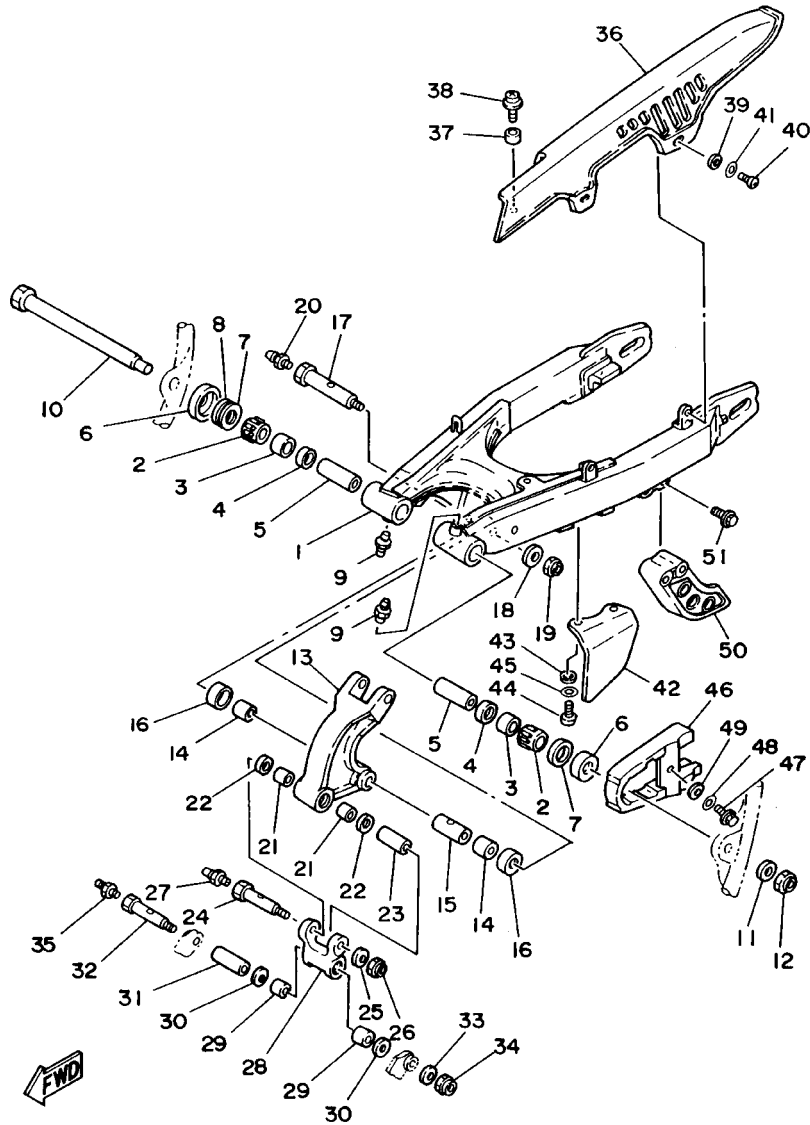

3NVK100-6240

REF. NO.	PART NO.	DESCRIPTION	3NVY	5LJ1	5LJ2	4FC9	REMARKS
1	55V-22110-00-P0	REAR ARM COMP.	1	1	1	1	GM1
2	93317-32231	BEARING	2	2	2	2	
3	90380-22111	BUSH, SOLID	2	2	2	2	
4	93106-22019	OIL SEAL (DC 22-28-8)	2	2	2	2	
5	30X-22123-00	BUSH 1	2	2	2	2	
6	322-22128-01	COVER, THRUST 1	2	2	2	2	
7	90201-243A2	WASHER, PLATE	2	2	2	2	
8	156-22127-00	SHIM (0.3T)	1	1	1	1	
9	93700-06004	NIPPLE, GREASE	2	2	2	2	
10	30X-22141-00	SHAFT, PIVOT	1	1	1	1	
11	90201-14215	WASHER, PLATE	1	1	1	1	
12	90185-14070	NUT, SELF-LOCKING	1	1	1	1	
13	30X-2217A-00	ARM, RELAY	1	1	1	1	
14	90386-20120	BUSH	2	2	2	2	
15	90387-140J9	COLLAR	1	1	1	1	
16	30X-22128-00	COVER, THRUST 1	2	2	2	2	
17	90109-121A1	BOLT	1	1	1	1	
18	90201-120A5	WASHER, PLATE	1	1	1	1	
19	90185-12119	NUT, SELF-LOCKING	1	1	1	1	
20	93700-06004	NIPPLE, GREASE	1	1	1	1	
21	90386-18115	BUSH	2	2	2	2	
22	93109-18020	OIL SEAL	2	2	2	2	
23	90387-126J8	COLLAR	1	1	1	1	
24	90109-10752	BOLT	1	1	1	1	
25	90201-100E9	WASHER, PLATE	1	1	1	1	
26	90185-10120	NUT, SELF-LOCKING	1	1	1	1	
27	93700-06009	NIPPLE, GREASE	1	1	1	1	

FIG. 24 REAR ARM

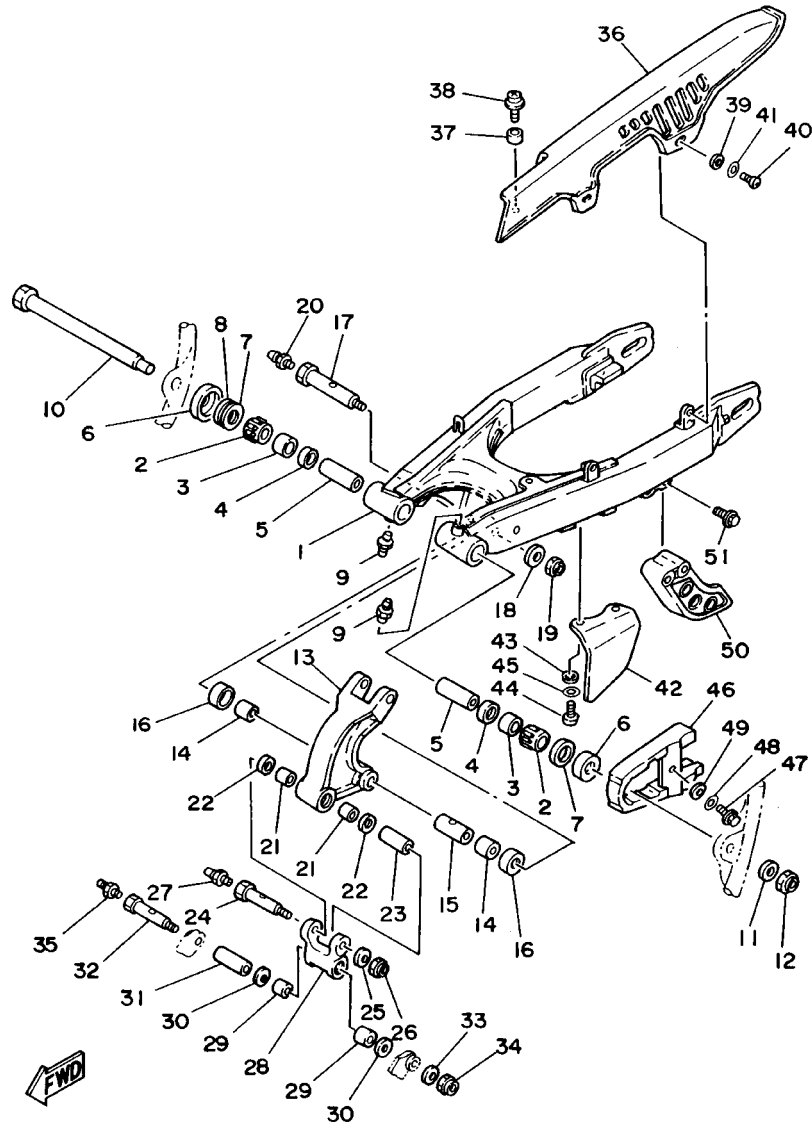

3NVK100-6240

REF. NO.	PART NO.	DESCRIPTION	3NVY	5LJ1	5LJ2	4FC9	REMARKS
28	30X-2217F-01	ROD, CONNECTING 1	1	1	1	1	
29	90386-18115	BUSH	2	2	2	2	
30	93109-18020	OIL SEAL	2	2	2	2	
31	90387-121L6	COLLAR	1	1	1	1	
32	90109-10752	BOLT	1	1	1	1	
33	90201-100E9	WASHER, PLATE	1	1	1	1	
34	90185-10120	NUT, SELF-LOCKING	1	1	1	1	
35	93700-06004	NIPPLE, GREASE	1	1	1	1	
36	38M-22311-00	CASE, CHAIN	1	1	1	1	
37	90387-066K1	COLLAR	1	1	1	1	
38	90159-06013	SCREW, WITH WASHER	1	1	1	1	
39	90209-06187	WASHER	2	2	2	2	
40	98507-06016	SCREW, PAN HEAD	2	2	2	2	
41	92907-06600	WASHER, PLATE	2	2	2	2	
42	30X-22312-01	CASE, CHAIN 2	1	1	1	1	
43	90209-06187	WASHER	2	2	2	2	
44	98507-06012	SCREW, PAN HEAD	2	2	2	2	
45	92907-06600	WASHER, PLATE	2	2	2	2	
46	42U-22151-01	SEAL, GUARD	1	1	1	1	
47	97007-06012	BOLT	1	1	1	1	
48	92907-06600	WASHER, PLATE	1	1	1	1	
49	90209-06187	WASHER	1	1	1	1	
50	30X-22153-00	GUARD, CHAIN	1	1	1	1	
51	95807-06050	BOLT, FLANGE	2	2	2	2	

FIG. 25 REAR SUSPENSION

REF. NO.	PART NO.	DESCRIPTION	3NVY	5LJ1	5LJ2	4FC9	REMARKS
1	3YT-22210-11-33	SHOCK ABSORBER ASSY, REAR	1	1			YB
	3YT-22210-30-33	SHOCK ABSORBER ASSY, REAR			1		YB
	3YT-22210-21-33	SHOCK ABSORBER ASSY, REAR				1	YB
2	30X-22216-00	.BUSH, REAR SHOCK ABSORBER	1	1	1	1	
3	30X-22226-00	.BUSH, SHOCK ABSORBER LOWER	1	1	1	1	
4	90384-18157	.BUSH, BIMETAL FORMED	2	2	2	2	
5	90109-10753	BOLT	1	1	1	1	
6	90201-100E9	WASHER, PLATE	1	1	1	1	
7	90185-10120	NUT, SELF-LOCKING	1	1	1	1	
8	30X-22129-00	COVER, THRUST 2	2	2	2	2	
9	90387-121J0	COLLAR	1	1	1	1	
10	90109-10753	BOLT	1	1	1	1	
11	90201-120E6	WASHER, PLATE	1	1	1	1	
12	90201-100E9	WASHER, PLATE	1	1	1	1	
13	90185-10120	NUT, SELF-LOCKING	1	1	1	1	

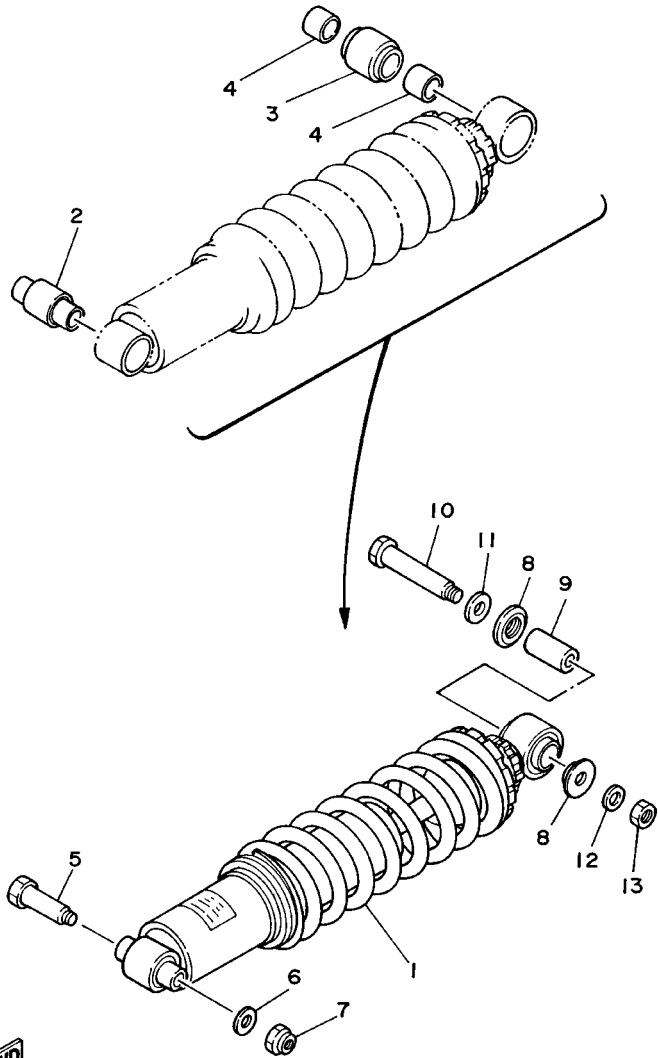

57R700-5220

FIG. 26 STEERING

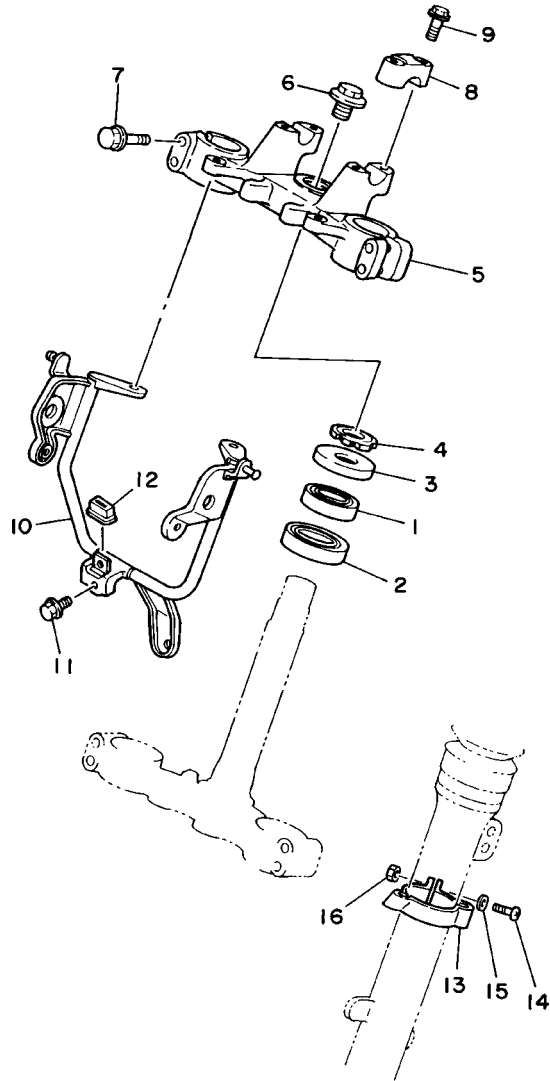

REF. NO.	PART NO.	DESCRIPTION	3NVY	5LJ1	5LJ2	4FC9	REMARKS
1	93332-00001	BEARING	1	1	1		
2	93332-00008	BEARING	1	1	1		
3	1W1-23416-00	COVER, BALL RACE 2	1	1	1		
4	90179-25033	NUT	1	1	1		
5	30X-23435-00-35	CROWN, HANDLE	1	1	1		SL
6	90105-14102	BOLT, WASHER BASED	1	1	1		
7	95027-08040	BOLT, FLANGE	4	4	4		
8	1E6-23441-10-35	HOLDER, HANDLE UPPER	2	2	2		SL
9	95824-08035	BOLT, FLANGE	4	4	4		
10	30X-23174-00	STAY, HEADLIGHT	1	1	1		
11	95807-06012	BOLT, FLANGE	1	1	1		
12	30X-23445-00	DAMPER	1	1	1		
13	34X-23317-00	HOLDER, CABLE	1	1	1		
14	98507-05018	SCREW, PAN HEAD	1	1	1		
15	92907-05600	WASHER, PLATE	1	1	1		
16	95307-05600	NUT	1	1	1		



57R700-5231

FIG. 27 STEERING 2

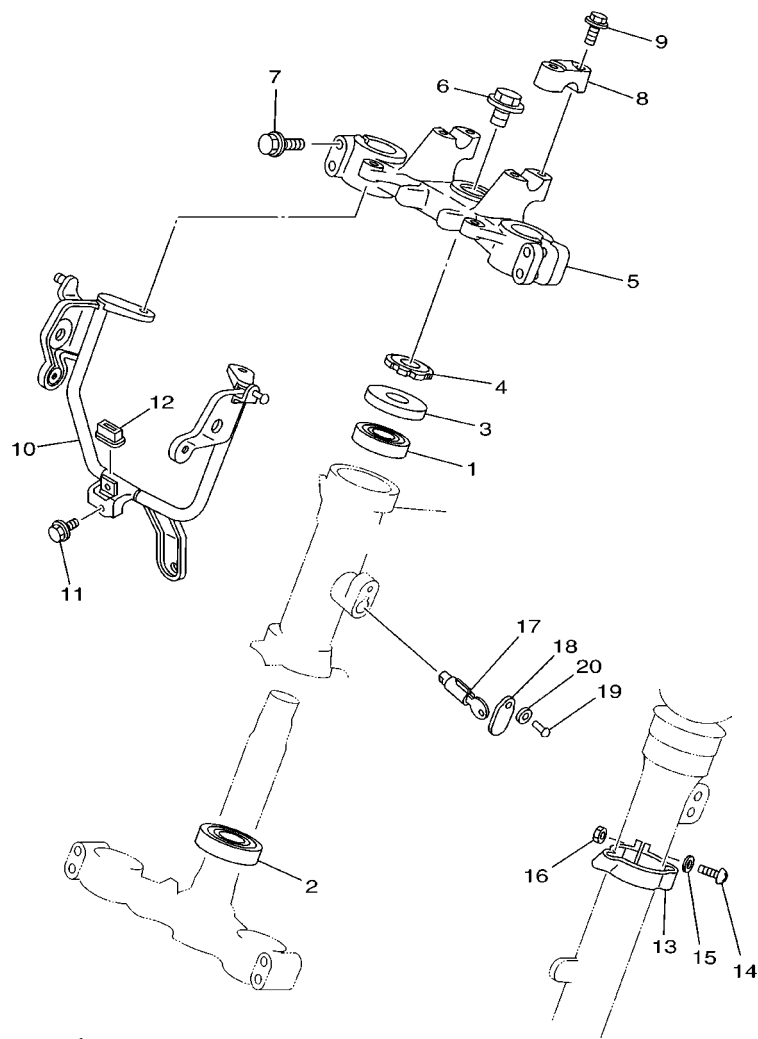

3NVY100-0270

REF. NO.	PART NO.	DESCRIPTION	3NVY	5LJ1	5LJ2	4FC9	REMARKS
1	93332-00001	BEARING				1	
2	93332-00008	BEARING				1	
3	1W1-23416-00	COVER, BALL RACE 2				1	
4	90179-25033	NUT				1	
5	30X-23435-00-35	CROWN, HANDLE				1	SL
6	90105-14102	BOLT, WASHER BASED				1	
7	95027-08040	BOLT, FLANGE				4	
8	1E6-23441-10-35	HOLDER, HANDLE UPPER				2	SL
9	95824-08035	BOLT, FLANGE				4	
10	30X-23174-00	STAY, HEADLIGHT				1	
11	95807-06012	BOLT, FLANGE				1	
12	30X-23445-00	DAMPER				1	
13	34X-23317-00	HOLDER, CABLE				1	
14	98507-05018	SCREW, PAN HEAD				1	
15	92907-05600	WASHER, PLATE				1	
16	95307-05600	NUT				1	
17	*	STEERING LOCK ASSY				1	LM
18	134-23484-10	CAP, HANDLE LOCK				1	
19	90269-04003	RIVET				1	
20	90208-04029	WASHER, CONICAL SPRING				1	

FIG. 28 FRONT FORK

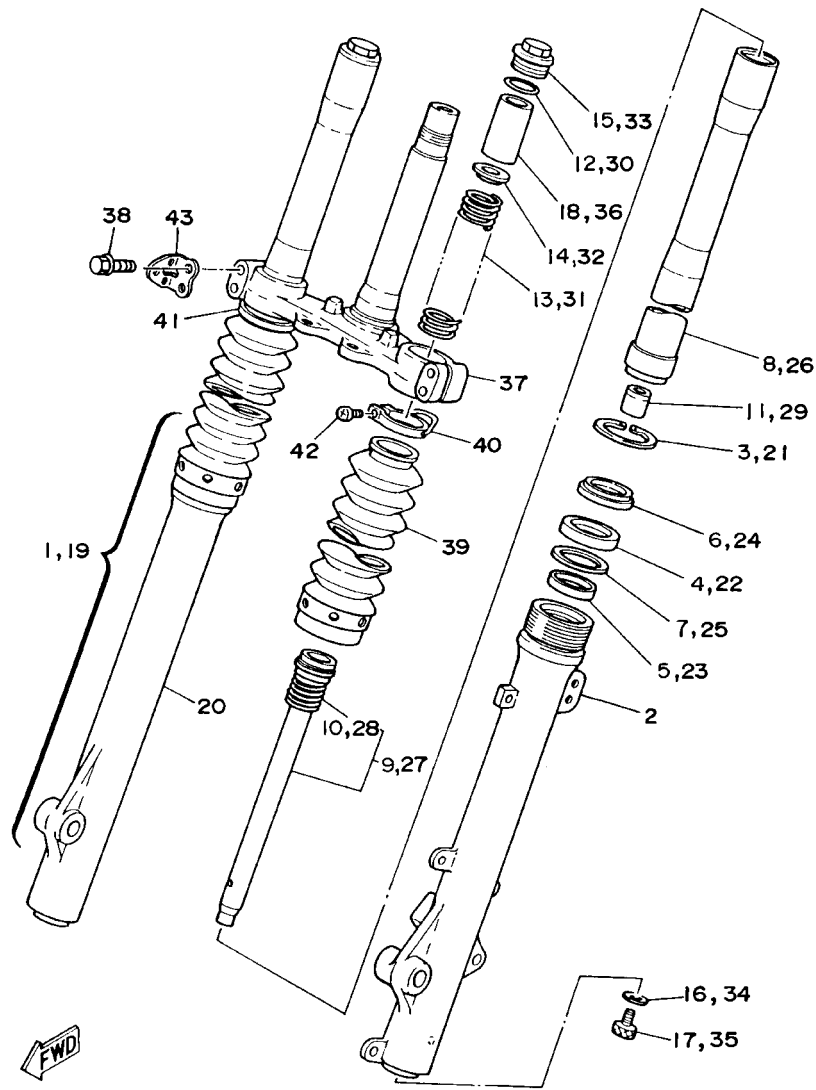

3NVK100-6280

REF. NO.	PART NO.	DESCRIPTION	3NVY	5LJ1	5LJ2	4FC9	REMARKS
1	55V-23102-A1	FRONT FORK ASSY (L.H)	1	1	1	1	
2	48Y-23126-01	.TUBE, OUTER (LEFT)	1	1	1	1	
3	4A1-23156-00	.CLIP, OIL SEAL	1	1	1	1	
4	48Y-23145-00	.OIL SEAL	1	1	1	1	
5	30X-23125-00	.METAL, SLIDE 1	1	1	1	1	
6	48Y-23144-00	.SEAL, DUST	1	1	1	1	
7	5K5-23149-00	.WASHER, SPRING UPPER	1	1	1	1	
8	30X-23110-00	.INNER TUBE COMP.1	1	1	1	1	
9	55V-23170-00	.CYLINDER COMP., FRONT FORK	1	1	1	1	
10	2X1-23151-00	.SPRING, REBOUND	1	1	1	1	
11	3R6-23173-L0	.SPINDLE, TAPER	1	1	1	1	
12	1W1-23114-L0	.GASKET	1	1	1	1	
13	30X-23141-00	.SPRING, FRONT FORK	1	1	1	1	
14	4FY-23149-00	.WASHER, SPRING UPPER	1	1	1	1	
15	53Y-23111-00	.BOLT, CAP	1	1	1	1	
16	509-23158-L0	.GASKET	1	1	1	1	
17	278-23181-50	.BOLT, HEXAGON SOCKET HEAD	1	1	1	1	
18	4V5-23118-L1	.SPACER	1	1	1	1	
19	55V-23103-A1	FRONT FORK ASSY (R.H)	1	1	1	1	
20	48Y-23136-01	.TUBE, OUTER (RIGHT)	1	1	1	1	
21	4A1-23156-00	.CLIP, OIL SEAL	1	1	1	1	
22	48Y-23145-00	.OIL SEAL	1	1	1	1	
23	30X-23125-00	.METAL, SLIDE 1	1	1	1	1	
24	48Y-23144-00	.SEAL, DUST	1	1	1	1	
25	5K5-23149-00	.WASHER, SPRING UPPER	1	1	1	1	
26	30X-23110-00	.INNER TUBE COMP.1	1	1	1	1	
27	55V-23170-00	.CYLINDER COMP., FRONT FORK	1	1	1	1	

FIG. 28 FRONT FORK

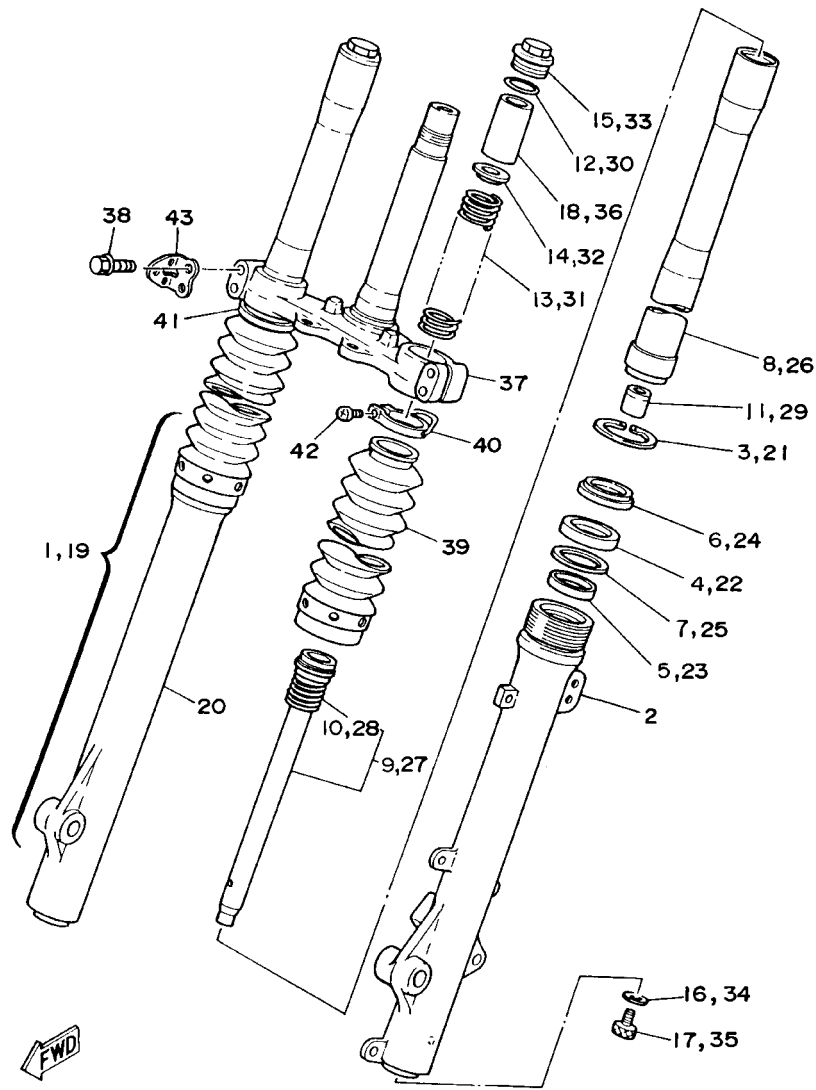

3NVK100-6280

REF. NO.	PART NO.	DESCRIPTION	3NVY	5LJ1	5LJ2	4FC9	REMARKS
28	2X1-23151-00	..SPRING, REBOUND	1	1	1	1	
29	3R6-23173-L0	.SPINDLE, TAPER	1	1	1	1	
30	1W1-23114-L0	.GASKET	1	1	1	1	
31	30X-23141-00	.SPRING, FRONT FORK	1	1	1	1	
32	4FY-23149-00	.WASHER, SPRING UPPER	1	1	1	1	
33	53Y-23111-00	.BOLT, CAP	1	1	1	1	
34	509-23158-L0	.GASKET	1	1	1	1	
35	278-23181-50	.BOLT, HEXAGON SOCKET HEAD	1	1	1	1	
36	4V5-23118-L1	.SPACER	1	1	1	1	
37	55V-23340-00	UNDER BRACKET COMP.	1	1	1	1	
38	95021-08040	BOLT, FLANGE	4	4	4	4	
39	3YT-23191-30	BOOT	2	2	2	2	FBL
40	48Y-23192-00	BAND	1	1	1	1	
41	341-92090-60	BAND, BOOT	1	1	1	1	
42	1W4-23194-L0	SCREW, BOOT BAND	2	2	2	2	
43	49R-85112-00	BRACKET, REFLECTOR 1	2	2	2		

FIG. 29 FUEL TANK

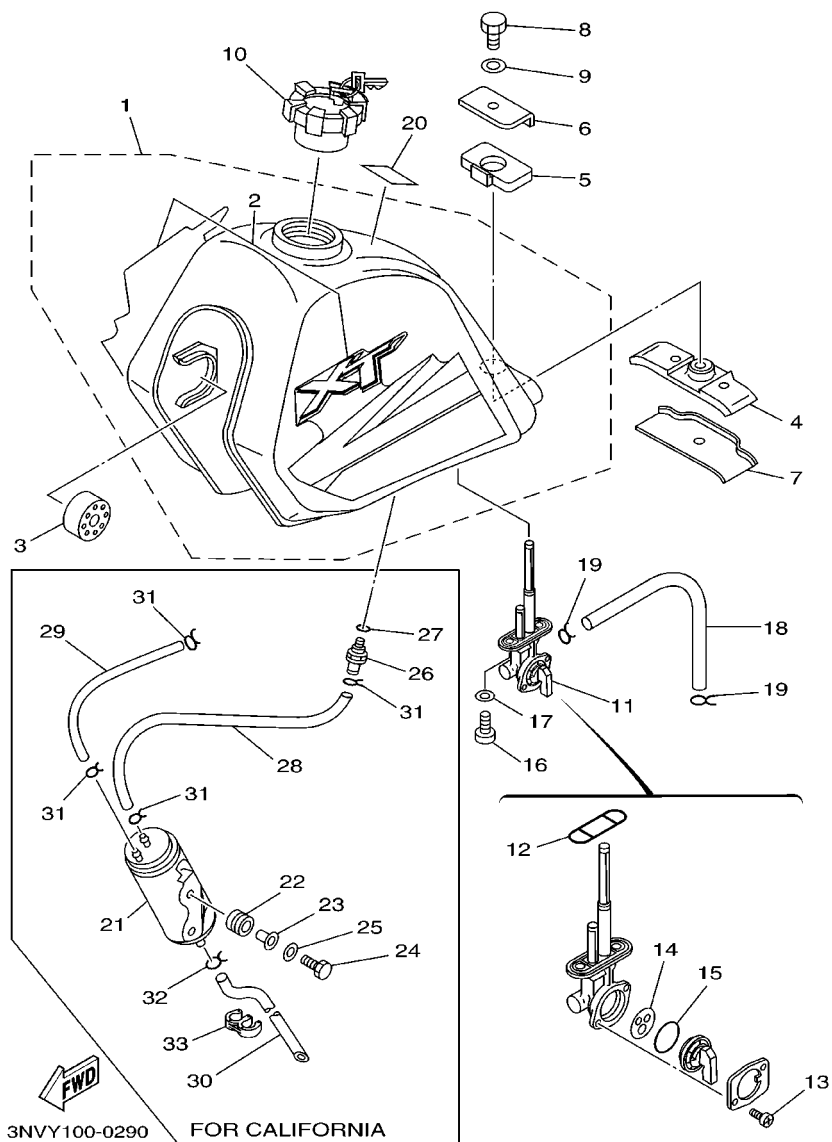

REF. NO.	PART NO.	DESCRIPTION	3NVY	5LJ1	5LJ2	4FC9	REMARKS
1	30X-Y2410-G0-01	FUEL TANK COMP.	1		1	1	PWS1
	43E-Y2410-10-01	FUEL TANK COMP.		1			PWS1
2	3NV-24240-70	.GRAPHIC SET	1	1	1	1	
3	4L0-24181-00	DAMPER, LOCATING 1	2	2	2	2	
4	30X-24182-01	DAMPER, LOCATING 2	1	1	1	1	
5	30X-24183-01	DAMPER, LOCATING 3	1	1	1	1	
6	30X-24186-01	WASHER, SPECIAL	1	1	1	1	
7	30X-24187-00	WASHER, SPECIAL	1	1	1	1	
8	97007-06012	BOLT	1	1	1	1	
9	92907-06600	WASHER, PLATE	1	1	1	1	
10	48Y-24602-00	CAP ASSY	1		1	1	
	56R-24602-00	CAP ASSY		1			
11	23F-24500-01	FUEL COCK ASSY 1	1	1	1	1	
12	4X8-24512-00	.O-RING	1	1	1	1	
13	97801-03008	.SCREW, PAN HEAD	2	2	2	2	
14	3AJ-24523-00	.VALVE PACKING	1	1	1	1	
15	3AJ-24534-00	.SEAL, COCK	1	1	1	1	
16	90149-06011	SCREW	2	2	2	2	
17	90202-05193	WASHER, PLATE	2	2	2	2	
18	90445-10008	HOSE	1	1	1	1	
19	90467-09006	CLIP	2	2	2	2	
20	3MX-2118K-A0	LABEL, CAUTION	1	1	1		
21	56R-24170-00	CANISTER ASSY		1			
22	90480-15342	GROMMET		2			
23	90387-063G3	COLLAR		2			
24	97007-06025	BOLT		2			
25	92907-06600	WASHER, PLATE		2			

FIG. 29 FUEL TANK

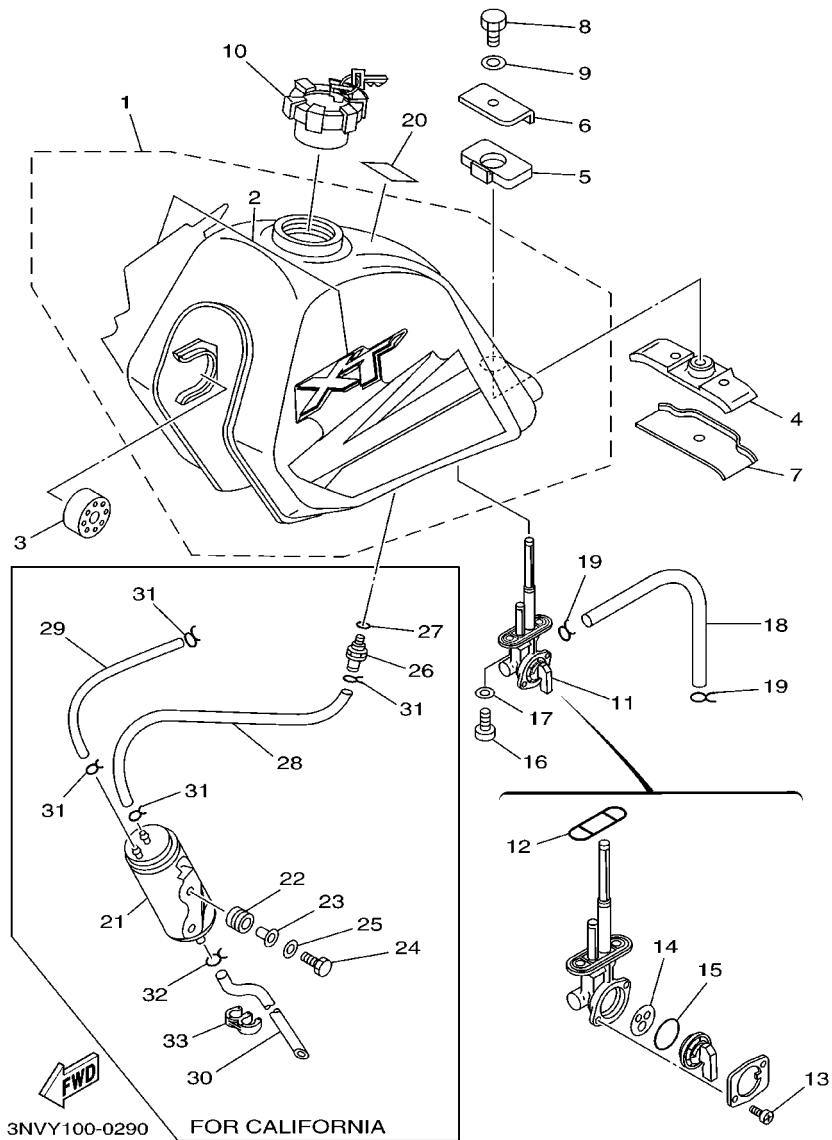

REF. NO.	PART NO.	DESCRIPTION	3NVY	5LJ1	5LJ2	4FC9	REMARKS
26	20K-24180-00	ROLL OVER VALVE ASSY		1			
27	93210-10166	O-RING		1			
28	56R-24314-00	PIPE 4		1			
29	43E-24315-00	PIPE 5		1			
30	91A21-07020	TUBE, FLEXIBLE		1			
31	90467-09006	CLIP		4			
32	90467-11106	CLIP		1			
33	90464-60067	CLAMP		1			

FIG. 30 SEAT

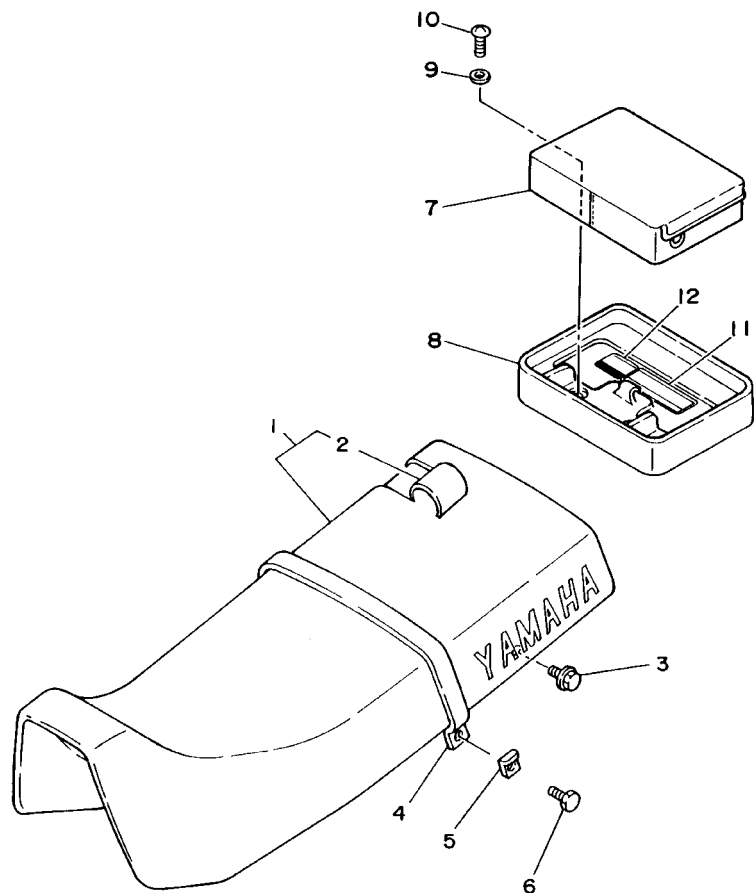

REF. NO.	PART NO.	DESCRIPTION	3NVY	5LJ1	5LJ2	4FC9	REMARKS
1	30X-24770-70	SEMI-DOUBLE SEAT ASSY	1	1	1		FBL
2	30X-2477A-70	.SEAT COVER ASSY	1	1	1		FBL
3	95807-06016	BOLT, FLANGE	2	2	2		
4	30X-24734-70	BAND, SEAT	1	1	1		FBL
5	92907-08200	WASHER	2	2	2		
6	97007-08014	BOLT	2	2	2		
7	38M-24850-00	CARRIER BOX ASSY	1	1	1		
8	30X-24833-00	BRACKET, CARRIER 2	1	1	1		
9	90201-06557	WASHER, PLATE	3	3	3		
10	98507-06016	SCREW, PAN HEAD	3	3	3		
11	3JJ-28446-A0	LABEL, CAUTION	1	1	1		
12	3TB-24877-A0	LABEL, CAUTION	1	1	1		



3NVK100-6300

FIG. 31 SEAT 2

REF. NO.	PART NO.	DESCRIPTION	3NVY	5LJ1	5LJ2	4FC9	REMARKS
1	30X-24770-70	SEMI-DOUBLE SEAT ASSY				1	FBL
2	30X-2477A-70	.SEAT COVER ASSY				1	FBL
3	95807-06016	BOLT, FLANGE				2	
4	55V-24830-20	SUB CARRIER ASSY				1	
5	95807-08016	BOLT, FLANGE				2	
6	95807-06010	BOLT, FLANGE				2	

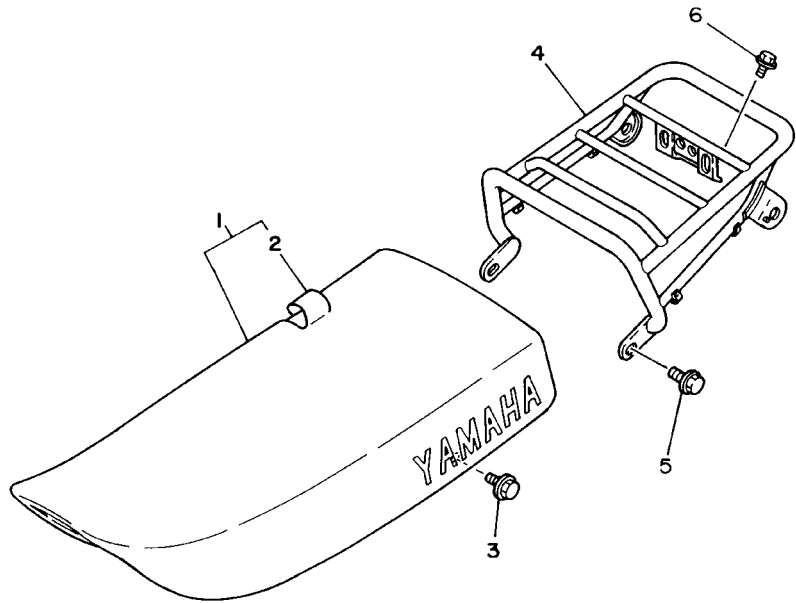

3NVG100-5310

FIG. 32 FRONT WHEEL

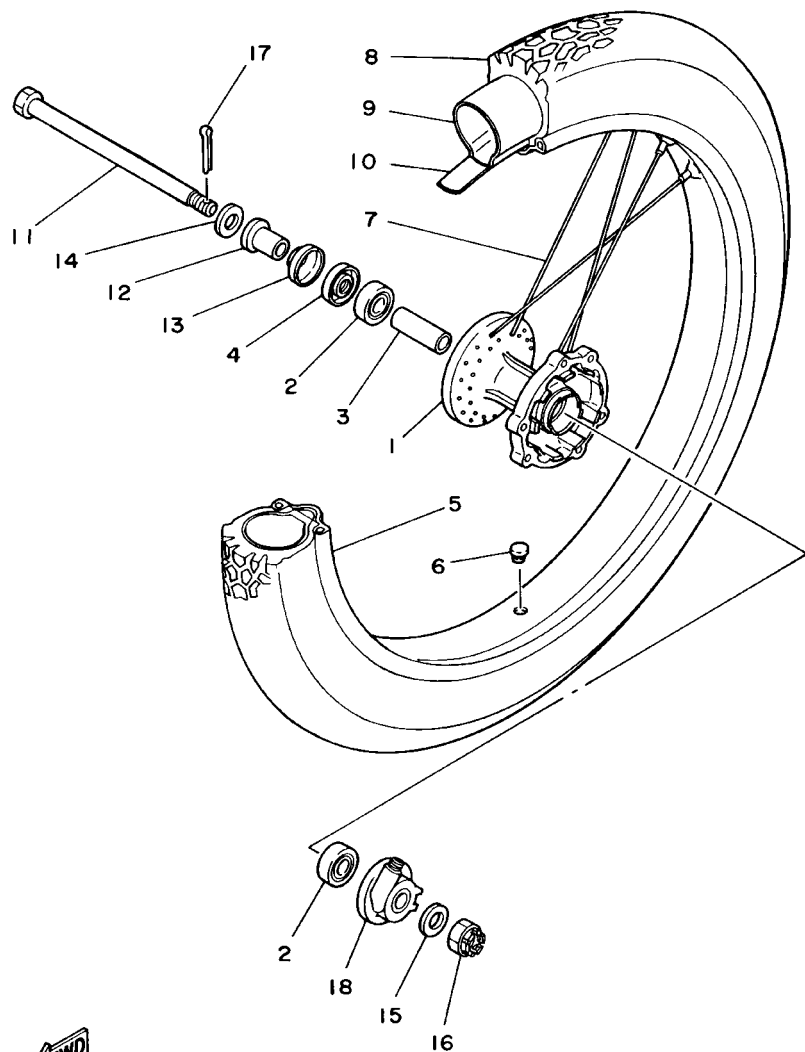

REF. NO.	PART NO.	DESCRIPTION	3NVY	5LJ1	5LJ2	4FC9	REMARKS
1	34X-25111-02-98	HUB, FRONT	1	1	1	1	LGB
2	93306-20205	BEARING (B6202)	2	2	2	2	
3	90560-15290	SPACER	1	1	1	1	
4	93102-20281	OIL SEAL (SD 20-35-5)	1	1	1	1	
5	94416-21419	RIM (1.60-21)	1	1	1	1	
6	90480-08608	GROMMET	1	1	1	1	
7	48Y-25104-00	SPOKE SET, FRONT	1	1	1	1	
8	94130-213G0	TIRE (3.00-21-4PR 51P TW25)	1	1	1	1	BRIDGESTONE
9	94227-21123	TUBE (2.75-21)	1	1	1	1	BRIDGESTONE
10	94330-21084	BAND, RIM (3.00-21)	1	1	1	1	BRIDGESTONE
11	30X-25181-00	AXLE, WHEEL	1	1	1	1	
12	90387-15600	COLLAR	1	1	1	1	
13	322-25118-00	COVER, HUB DUST	1	1	1	1	
14	90201-163H8	WASHER, PLATE	1	1	1	1	
15	90201-15785	WASHER, PLATE	1	1	1	1	
16	90171-14020	NUT, CASTLE	1	1	1	1	
17	91401-30030	PIN, COTTER	1	1	1	1	
18	34X-25190-01	GEAR UNIT ASSY	1	1	1	1	

 57R700-5270

FIG. 33 FRONT BRAKE CALIPER

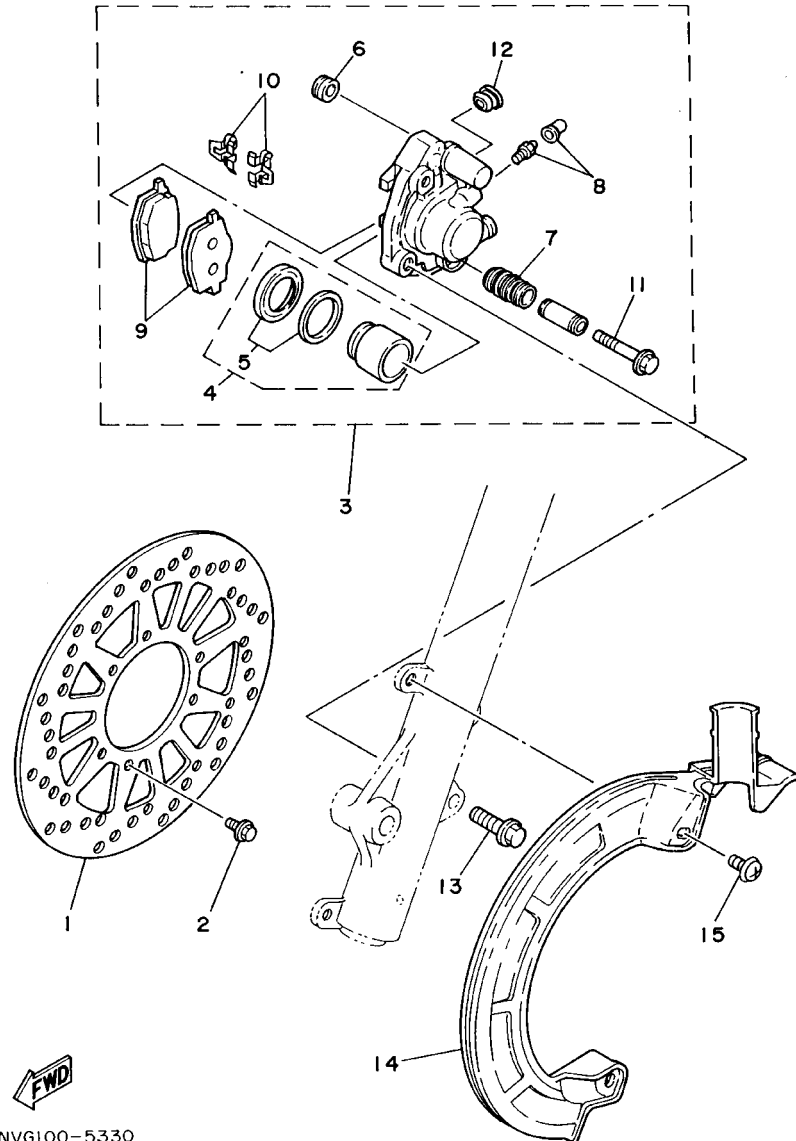

REF. NO.	PART NO.	DESCRIPTION	3NVY	5LJ1	5LJ2	4FC9	REMARKS
1	48Y-25831-00	DISC, BRAKE (RIGHT)	1	1	1	1	
2	90109-065G4	BOLT	6	6	6	6	
3	59Y-2580T-10	CALIPER ASSY (LEFT)	1	1	1	1	
4	34X-W0057-00	.PISTON ASSY, CALIPER	1	1	1	1	
5	34X-W0047-00	..CALIPER SEAL KIT	1	1	1	1	
6	5R2-25937-00	.BOOT 2	1	1	1	1	
7	34X-25937-00	.BOOT 2	1	1	1	1	
8	51L-W0048-00	.BLEED SCREW KIT	1	1	1	1	
9	38W-W0045-02	.BRAKE PAD KIT	1	1	1	1	
10	34X-25919-00	.SUPPORT, PAD	2	2	2	2	
11	2GV-25926-00	.BOLT	1	1	1	1	
12	34X-25845-00	.CAP, INDICATOR	1	1	1	1	
13	90105-10259	BOLT, WASHER BASED	2	2	2	2	
14	55V-25715-20	COVER 1	1	1	1	1	PWS1
15	90159-06181	SCREW, WITH WASHER	2	2	2	2	

FIG. 34 REAR WHEEL

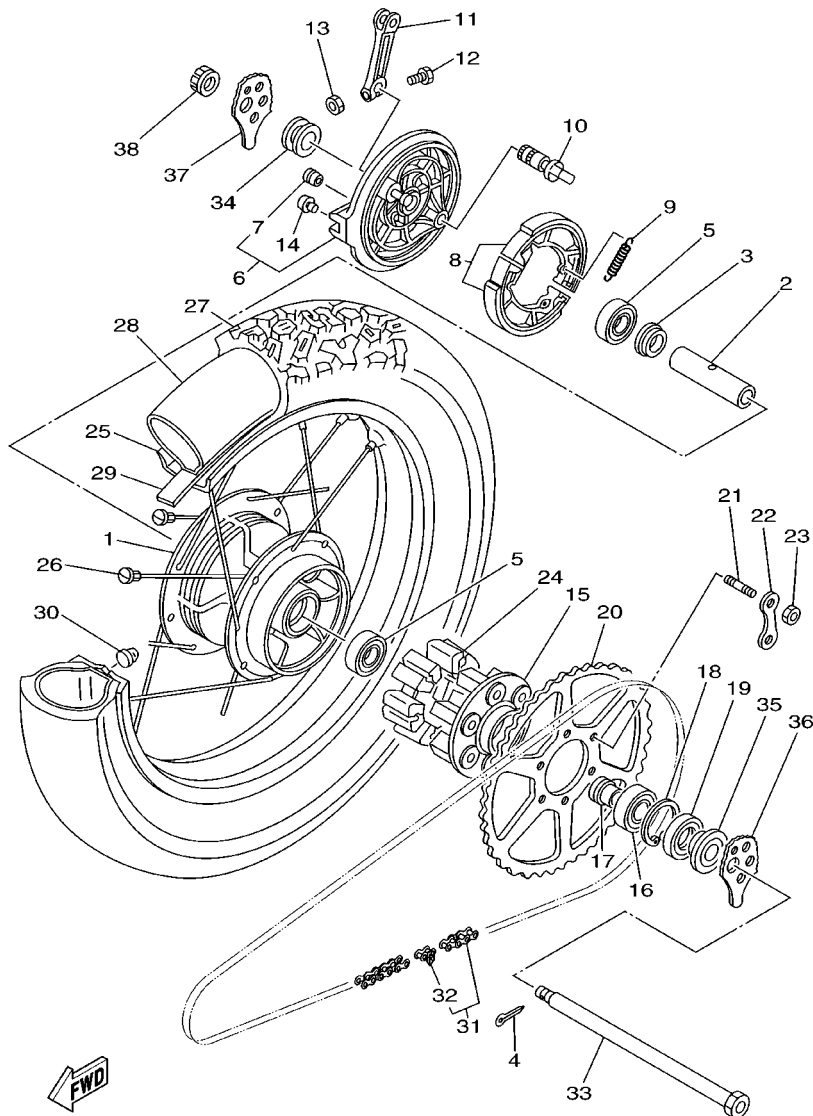

3NVY100-0340

REF. NO.	PART NO.	DESCRIPTION	3NVY	5LJ1	5LJ2	4FC9	REMARKS
1	3Y1-25311-00-98	HUB, REAR	1	1	1	1	LGB
2	90560-17311	SPACER	1	1	1	1	
3	146-25315-00	FLANGE, SPACER	1	1	1	1	
4	91401-30030	PIN, COTTER	1	1	1	1	
5	93306-20310	BEARING (B6203DU)	2	2	2	2	
6	3Y1-25026-00-98	BRAKE SHOE PLATE ASSY	1	1	1	1	LGB
7	90480-10068	GROMMET	1	1	1	1	
8	3LS-W2536-00	BRAKE SHOE SET	1	1	1	1	
9	90506-15260	SPRING, TENSION	2	2	2	2	
10	538-25351-01	CAMSHAFT	1	1	1	1	
11	3R6-25355-01	LEVER, CAMSHAFT	1	1	1	1	
12	90101-06278	BOLT	1	1	1	1	
13	95307-06600	NUT	1	1	1	1	
14	90480-10068	GROMMET	1	1	1	1	
15	3Y1-25366-00-98	CLUTCH, HUB	1	1	1	1	LGB
16	93306-20446	BEARING	1	1	1	1	
17	3Y1-25377-00	COLLAR, WHEEL	1	1	1	1	
18	99009-47500	CIRCLIP	1	1	1	1	
19	93102-28022	OIL SEAL	1	1	1	1	
20	55V-25455-50	SPROCKET, DRIVEN (55T)	1	1	1		
	55V-25452-50	SPROCKET, DRIVEN (52T)				1	
21	90116-08425	BOLT, STUD	6	6	6	6	
22	90215-08160	WASHER, LOCK	3	3	3	3	
23	90170-08258	NUT	6	6	6	6	
24	3Y1-25364-00	DAMPER	6	6	6	6	
25	94421-18418	RIM (2.15-18)	1	1	1	1	
26	4Y0-25304-00	SPOKE SET, REAR	1	1	1	1	

FIG. 34 REAR WHEEL

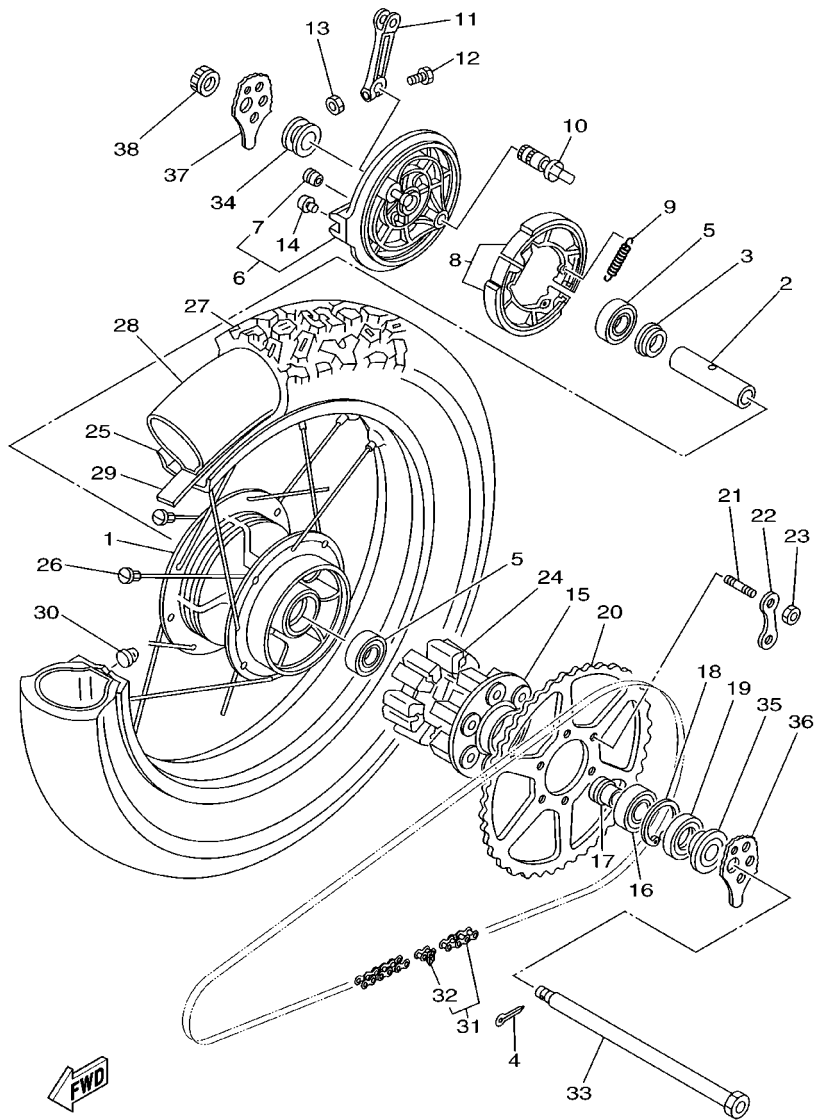

3NVY100-0340

REF. NO.	PART NO.	DESCRIPTION	3NVY	5LJ1	5LJ2	4FC9	REMARKS
27	94111-182G9	TIRE (110/80-18-58P)	1	1	1	1	BRIDGESTONE
28	94237-18120	TUBE (3.75-18)	1	1	1	1	BRIDGESTONE
29	94340-18086	BAND, RIM (4.00-18)	1	1	1	1	BRIDGESTONE
30	90480-08608	GROMMET	1	1	1	1	
31	94581-61130	CHAIN (DID428VS3-130LL)	1	1	1		
	94581-61128	CHAIN (DID428VS3-128LL)				1	
32	94681-61011	.JOINT, CHAIN (DID428VS-FJ)	1	1	1	1	
33	4KM-25181-00	AXLE, WHEEL	1	1	1	1	
34	90387-17141	COLLAR	1	1	1	1	
35	3Y1-25383-00	COLLAR, WHEEL	1	1	1	1	
36	3Y1-25388-01	PULLER, CHAIN 1	1	1	1	1	
37	3Y1-25389-00	PULLER, CHAIN 2	1	1	1	1	
38	90171-16024	NUT, CASTLE	1	1	1	1	

FIG. 35 STEERING HANDLE. CABLE

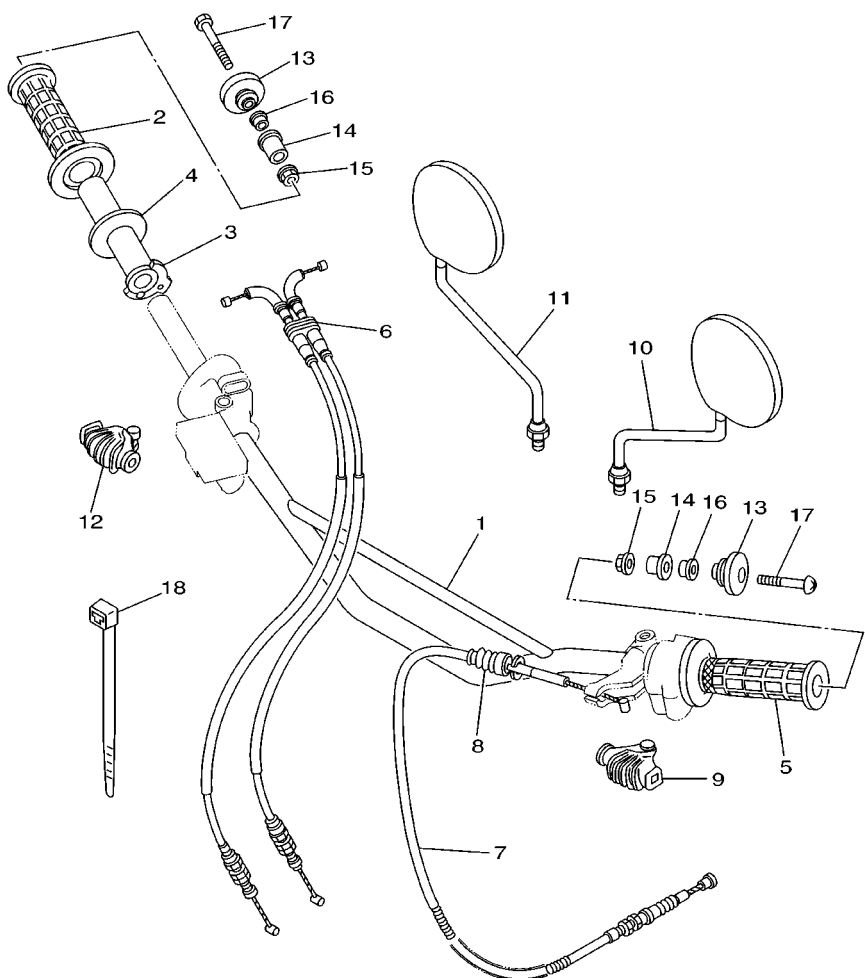

REF. NO.	PART NO.	DESCRIPTION	3NVY	5LJ1	5LJ2	4FC9	REMARKS
1	1EU-26111-20	HANDLEBAR	1	1	1	1	
2	55V-26242-00	GRIP (RIGHT)	1	1	1	1	
3	1RF-26243-00	TUBE, THROTTLE GUIDE	1	1	1	1	
4	3Y1-26249-00	RING, LEAF	1	1	1	1	
5	55V-26241-00	GRIP (LEFT)	1	1	1	1	
6	30X-26302-01	THROTTLE CABLE ASSY	1	1	1	1	
7	30X-26335-01	CABLE, CLUTCH	1	1	1	1	
8	1E6-26342-00	BOOT, CABLE	1	1	1	1	
9	1E6-26372-00	COVER, HANDLE LEVER 1	1	1	1	1	
10	3Y1-26290-10	BACK MIRROR ASSY (L.H)	1	1	1		
	1Y1-26290-50	BACK MIRROR ASSY (L.H)				1	
11	3Y1-26290-00	BACK MIRROR ASSY (R.H)	1	1	1		
	1Y1-26290-60	BACK MIRROR ASSY (R.H)				1	
12	1T5-26372-00	COVER, HANDLE LEVER 1	1	1	1	1	
13	55V-26246-00	END, GRIP	2	2	2	2	
14	55V-2622F-00	DAMPER, LOCATING 1	2	2	2	2	
15	90179-06498	NUT	2	2	2	2	
16	90387-06681	COLLAR	2	2	2	2	
17	98507-06040	SCREW, PAN HEAD	2	2	2	2	
18	5A8-82591-00	BAND	1	1	1	1	

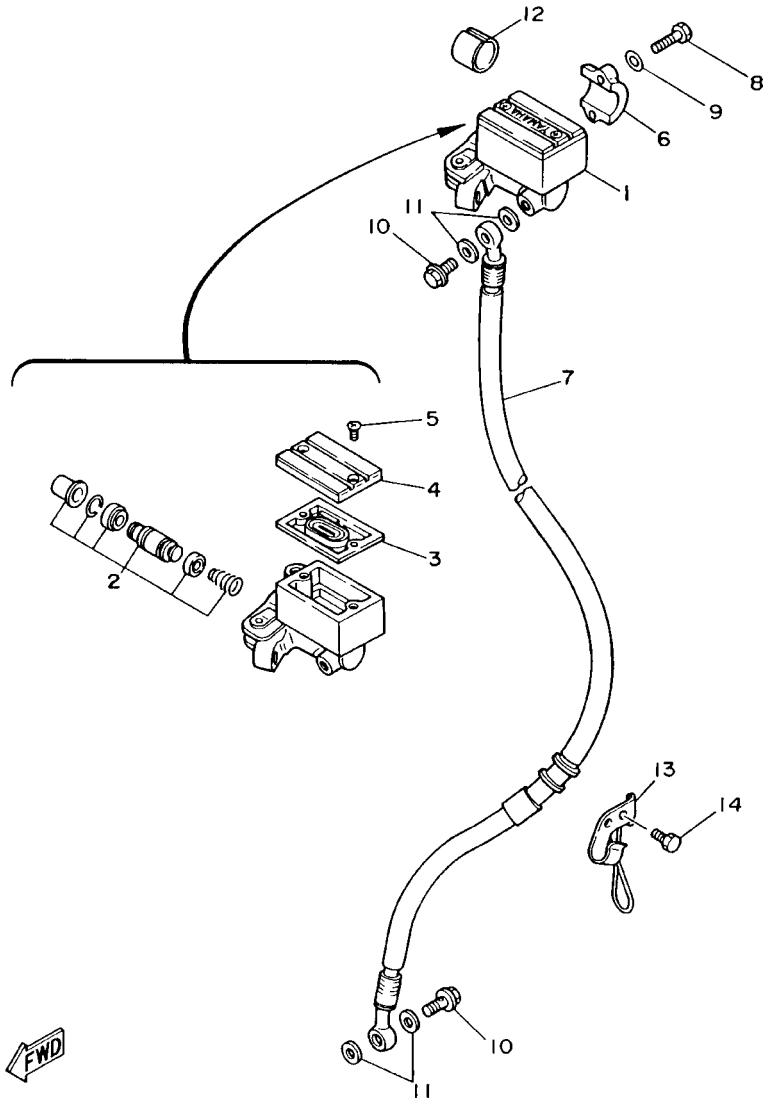

3NVY100-0350

FIG. 36 FRONT MASTER CYLINDER

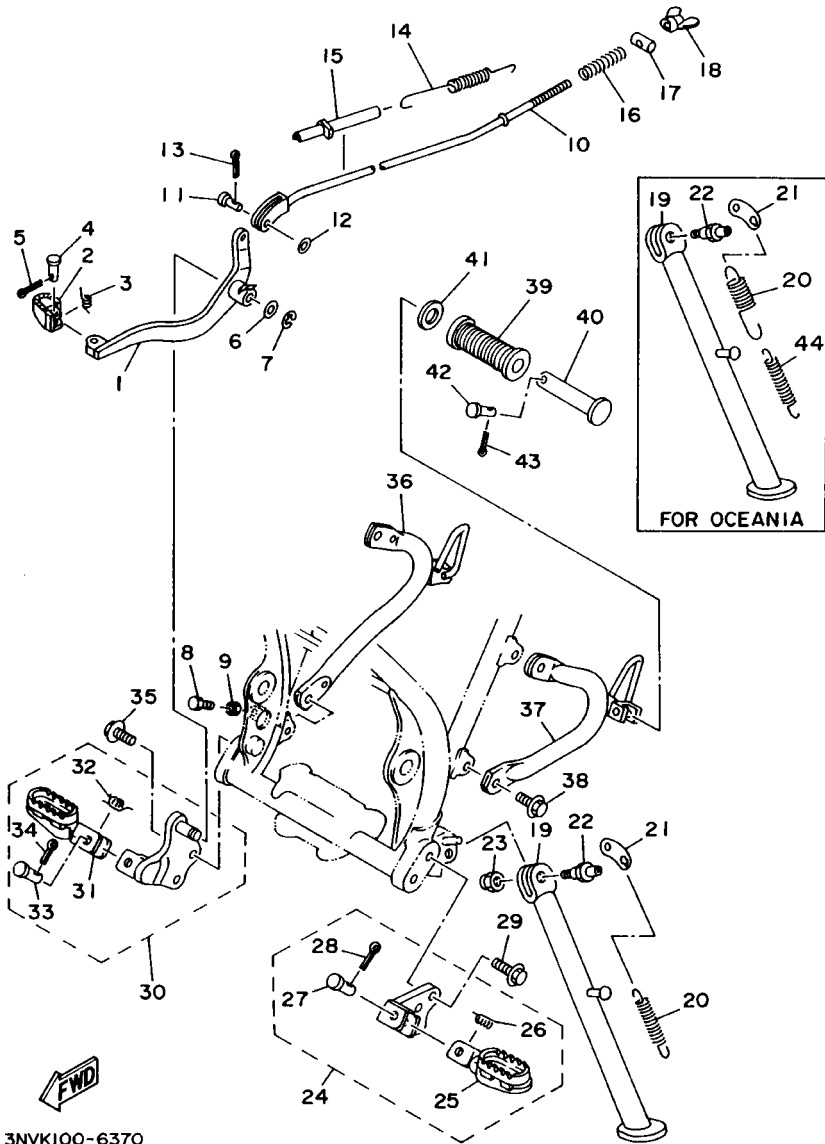

3NVK100-6360

REF. NO.	PART NO.	DESCRIPTION	3NVY	5LJ1	5LJ2	4FC9	REMARKS
1	39F-25870-00	MASTER CYLINDER SUB ASSY	1	1	1	1	
2	56A-W0041-00	.CYLINDER KIT, MASTER	1	1	1	1	
3	4L0-25854-00	.DIAPHRAGM, RESERVOIR	1	1	1	1	
4	4L3-25852-00	.CAP, RESERVOIR	1	1	1	1	
5	98706-04012	.SCREW, FLAT HEAD	2	2	2	2	
6	4L0-25867-00	BRACKET, MASTER CYLINDER	1	1	1	1	
7	48Y-25872-03	HOSE, BRAKE 1	1	1	1	1	
8	97007-06025	BOLT	2	2	2	2	
9	92907-06600	WASHER, PLATE	2	2	2	2	
10	90401-10159	BOLT, UNION	2	2	2	2	
11	90201-10118	WASHER, PLATE	4	4	4	4	
12	90387-227H7	COLLAR	1	1	1	1	
13	34X-25876-00	HOLDER, BRAKE HOSE 2	1	1	1	1	
14	91317-06010	BOLT	2	2	2	2	



3NVK100-6370

FIG. 37 STAND, FOOTREST

REF. NO.	PART NO.	DESCRIPTION	3NVY	5LJ1	5LJ2	4FC9	REMARKS
1	55V-27211-00	PEDAL, BRAKE	1	1	1	1	
2	55V-27242-00	PEDAL, BRAKE	1	1	1	1	
3	90508-14352	SPRING, TORSION	1	1	1	1	
4	91701-06022	PIN, CLEVIS	1	1	1	1	
5	91401-20012	PIN, COTTER	1	1	1	1	
6	90201-12541	WASHER, PLATE	1	1	1	1	
7	93430-09038	CIRCLIP	1	1	1	1	
8	90101-06288	BOLT	1	1	1	1	
9	95307-06700	NUT	1	1	1	1	
10	30X-27231-00	ROD, BRAKE	1	1	1	1	
11	90240-06076	PIN, CLEVIS	1	1	1	1	
12	92907-06200	WASHER	1	1	1	1	
13	91401-20012	PIN, COTTER	1	1	1	1	
14	90506-18154	SPRING, TENSION	1	1	1	1	
15	1M1-27244-00	COVER	1	1	1	1	
16	90501-10245	SPRING, COMPRESSION	1	1	1	1	
17	90249-12008	PIN	1	1	1	1	
18	90175-06013	NUT, WING	1	1	1	1	
19	55V-27311-02	STAND, SIDE	1	1	1	1	
20	90506-29276	SPRING, TENSION	1	1	1		
	90506-26225	SPRING, TENSION				1	
21	42U-27315-01	LINK, SIDE STAND	1	1	1	1	
22	90109-10635	BOLT	1	1	1	1	
23	90185-10037	NUT, SELF-LOCKING	1	1	1	1	
24	30X-27410-00-90	FRONT FOOTREST ASSY (LEFT)	1	1	1	1	ZK
25	22W-27411-01-90	FOOTREST	1	1	1	1	ZK
26	90508-20023	SPRING, TORSION	1	1	1	1	

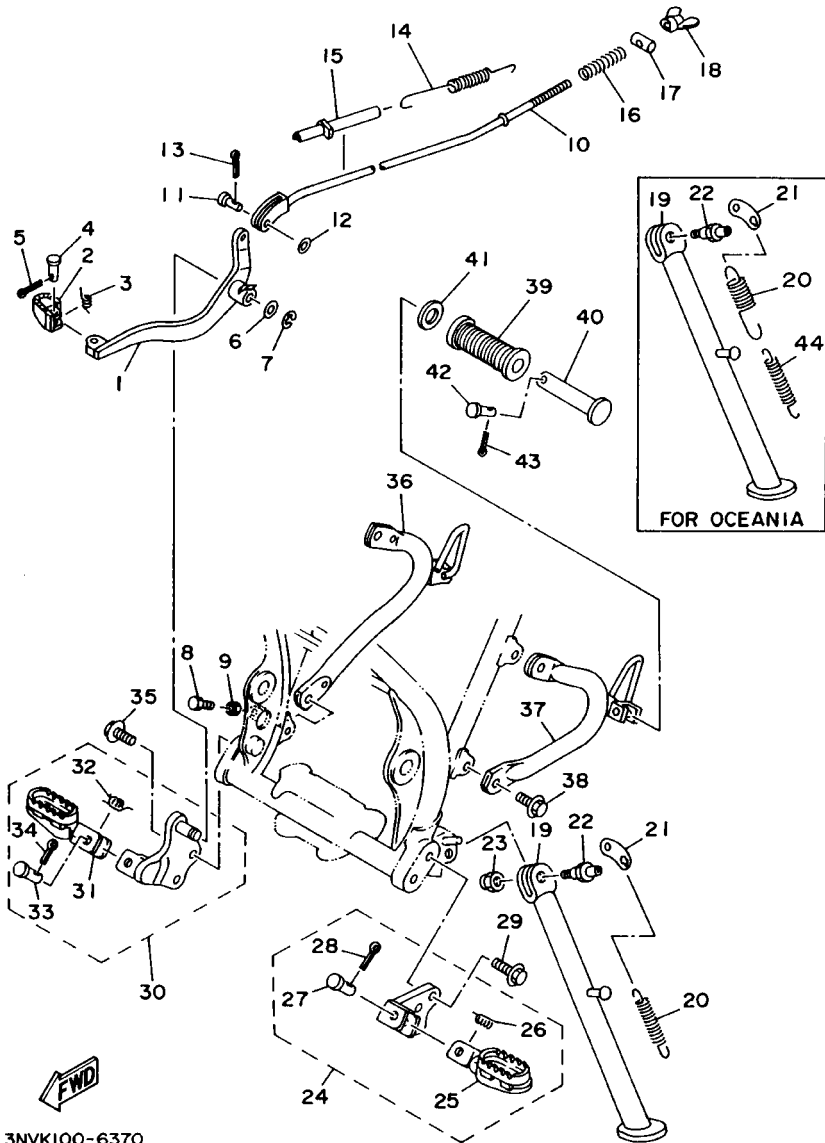

3NVK100-6370

FIG. 37 STAND. FOOTREST

REF. NO.	PART NO.	DESCRIPTION	3NVY	5LJ1	5LJ2	4FC9	REMARKS
27	90240-08084	.PIN, CLEVIS	1	1	1	1	
28	91401-25012	.PIN, COTTER	1	1	1	1	
29	95817-08020	BOLT, FLANGE	2	2	2	2	
30	55V-27420-00-90	FRONT FOOTREST ASSY (RIGHT)	1	1	1	1	ZK
31	22W-27421-01-90	.FOOTREST 2	1	1	1	1	ZK
32	90508-20023	.SPRING, TORSION	1	1	1	1	
33	90240-08084	.PIN, CLEVIS	1	1	1	1	
34	91401-25012	.PIN, COTTER	1	1	1	1	
35	95817-08020	BOLT, FLANGE	2	2	2	2	
36	55V-27442-00-33	BRACKET 2	1	1	1	1	YB
37	26F-27432-00-33	BRACKET 1	1	1	1	1	YB
38	92017-08016	BOLT, BUTTON HEAD	4	4	4	4	
39	120-27433-00	COVER, REAR FOOTREST	2	2	2	2	
40	120-27431-00	FOOTREST, REAR 1	2	2	2	2	
41	90201-20279	WASHER, PLATE	2	2	2	2	
42	91701-06032	PIN, CLEVIS	2	2	2	2	
43	91401-20012	PIN, COTTER	2	2	2	2	
44	90506-18224	SPRING, TENSION				1	

FIG. 38 COWLING 1

REF. NO.	PART NO.	DESCRIPTION	3NVY	5LJ1	5LJ2	4FC9	REMARKS
1	30X-Y2835-60	COWLING ASS'Y	1	1	1	1	
2	99247-00100	.EMBLEM, YAMAHA	1	1	1	1	
3	90480-12053	GROMMET	2	2	2	2	
4	90159-06060	SCREW, WITH WASHER	1	1	1	1	

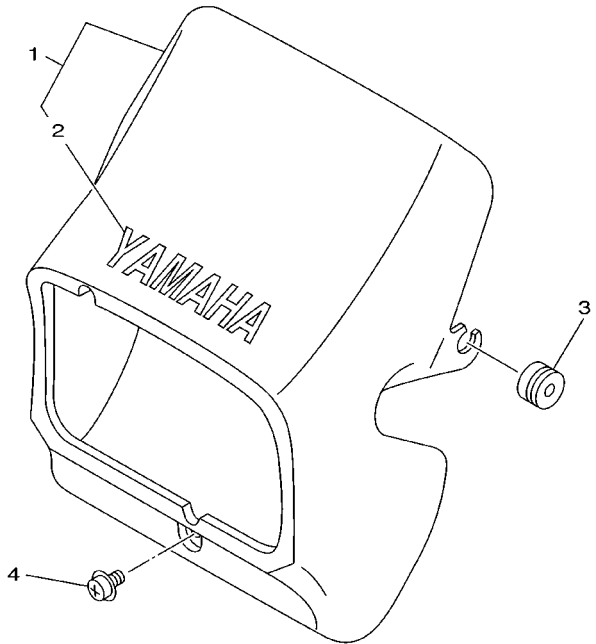

 3NVS100-8380

FIG. 39 GENERATOR

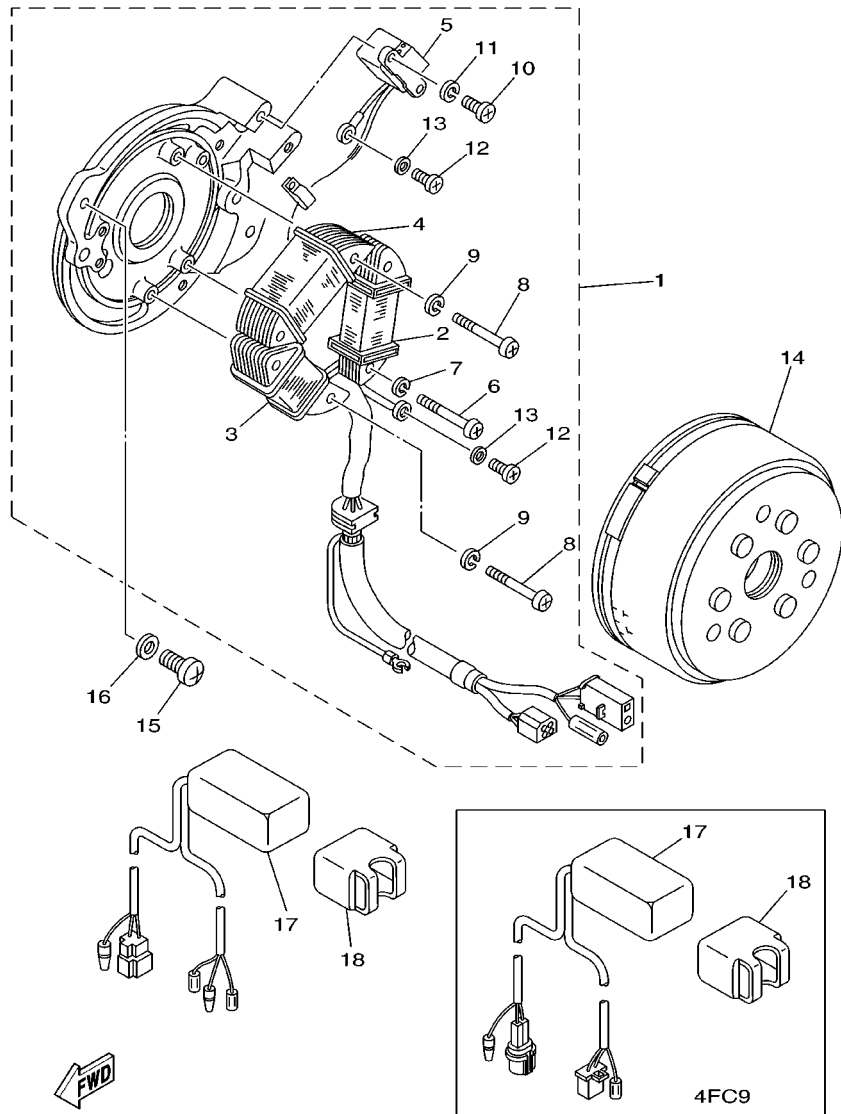

REF. NO.	PART NO.	DESCRIPTION	3NVY	5LJ1	5LJ2	4FC9	REMARKS
1	2GK-85510-21	STATOR ASSY	1	1	1		
	4FC-85510-00	STATOR ASSY				1	
2	55V-85512-00	.COIL, SOURCE	1	1	1	1	
3	56R-85513-00	.COIL, LIGHTING 1	1	1	1		
	30X-85513-00	.COIL, LIGHTING 1				1	
4	56R-85514-00	.COIL, LIGHTING 2	1	1	1		
	30X-85514-00	.COIL, LIGHTING 2				1	
5	30X-85580-00	.COIL, PULSER	1	1	1	1	
6	98501-05020	.SCREW, PAN HEAD	2	2	2	2	
7	92901-05100	.WASHER, SPRING	2	2	2	2	
8	98501-05035	.SCREW, PAN HEAD	4	4	4	4	
9	92901-05100	.WASHER, SPRING	4	4	4	4	
10	98501-05012	.SCREW, PAN HEAD	2	2	2	2	
11	92901-05100	.WASHER, SPRING	2	2	2	2	
12	98501-04008	.SCREW, PAN HEAD	2	2	2	2	
13	92901-04100	.WASHER, SPRING	2	2	2	2	
14	55V-85550-21	ROTOR ASSY	1	1	1	1	
15	98507-06016	SCREW, PAN HEAD	2	2	2	2	
16	92907-06600	WASHER, PLATE	2	2	2	2	
17	2GK-85540-20	C.D.I. UNIT ASSY	1	1	1		
	4FC-85540-00	C.D.I. UNIT ASSY				1	
18	3M5-85546-00	BAND	1	1	1	1	

FIG. 40 FLASHER LIGHT

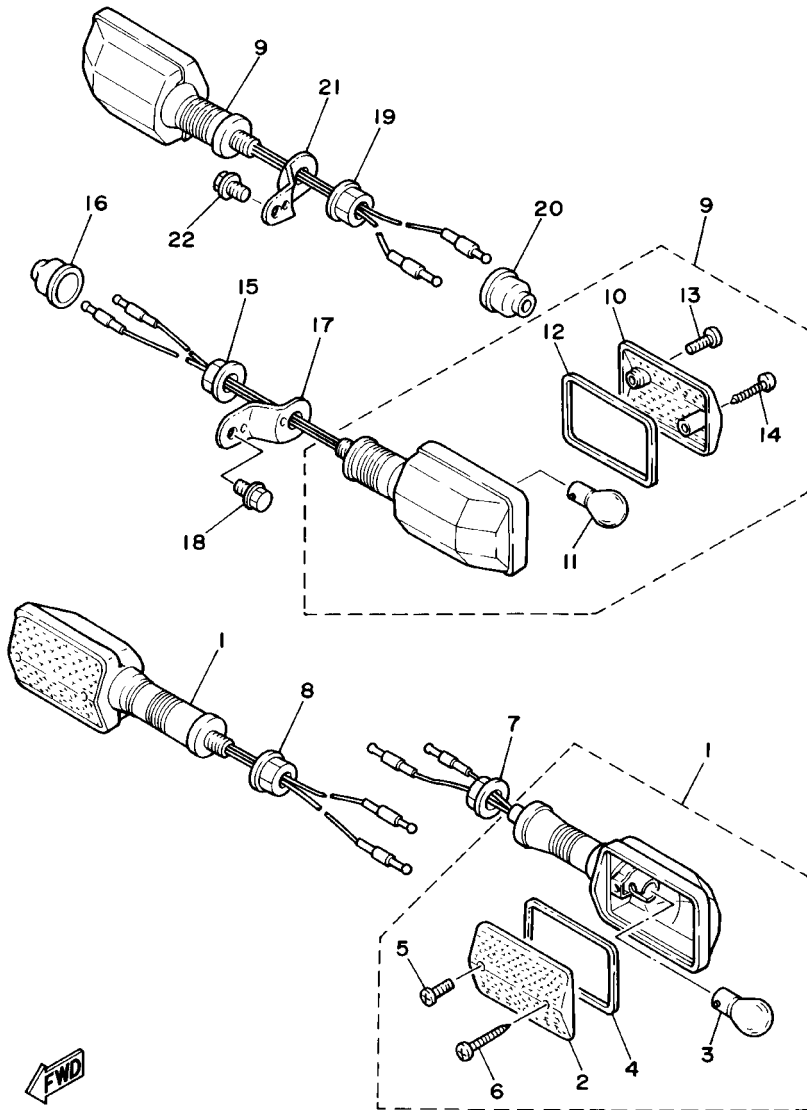

REF. NO.	PART NO.	DESCRIPTION	3NVY	5LJ1	5LJ2	4FC9	REMARKS
1	5Y1-83310-70	FRONT FLASHER LIGHT ASSY 1	2	2	2		
2	5Y1-83312-00	.LENS, FLASHER	1	1	1		
3	256-83311-70	.BULB (12V-27W)	1	1	1		
4	5Y1-83313-00	.GASKET, FLASHER LENS	1	1	1		
5	98502-04010	.SCREW, PAN HEAD	1	1	1		
6	97702-40530	.SCREW, TAPPING	1	1	1		
7	95307-12700	NUT	1	1	1		
8	95307-12700	NUT	1	1	1		
9	5Y1-83330-70	REAR FLASHER LIGHT ASSY 1	2	2	2		
10	5Y1-83312-00	.LENS, FLASHER	1	1	1		
11	256-83311-70	.BULB (12V-27W)	1	1	1		
12	5Y1-83313-00	.GASKET, FLASHER LENS	1	1	1		
13	98502-04010	.SCREW, PAN HEAD	1	1	1		
14	97702-40530	.SCREW, TAPPING	1	1	1		
15	95307-12700	NUT	1	1	1		
16	10V-83365-00	CAP	1	1	1		
17	10V-83368-00	STAY, FLASHER 1	1	1	1		
18	95027-08012	BOLT, FLANGE	1	1	1		
19	95307-12700	NUT	1	1	1		
20	10V-83365-00	CAP	1	1	1		
21	10V-83369-00	STAY, FLASHER 2	1	1	1		
22	95027-08012	BOLT, FLANGE	1	1	1		

FWD
30X010-3330

FIG. 41 FLASHER LIGHT 2

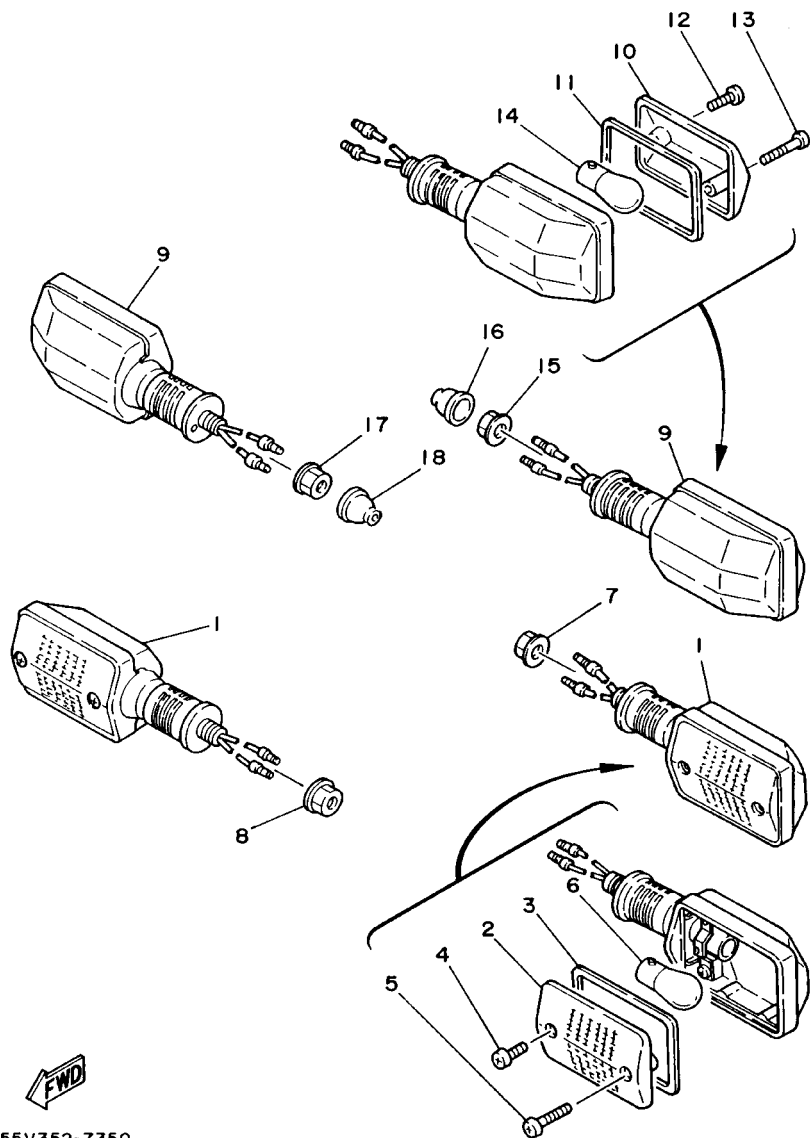

55V352-7350

REF. NO.	PART NO.	DESCRIPTION	3NVY	5LJ1	5LJ2	4FC9	REMARKS
1	5Y3-83310-21	FRONT FLASHER LIGHT ASSY 1				2	
2	5Y1-83312-00	.LENS, FLASHER				1	
3	5Y1-83313-00	.GASKET, FLASHER LENS				1	
4	98501-04012	.SCREW, PAN HEAD				1	
5	97702-40630	.SCREW, TAPPING				1	
6	306-83311-40	.BULB, FLASHER (12V-21W)				1	
7	95307-12700	NUT				1	
8	95307-12700	NUT				1	
9	37A-83330-21	REAR FLASHER LIGHT ASSY 1				2	
10	5Y3-83312-00	.LENS, FLASHER				1	
11	5Y1-83313-00	.GASKET, FLASHER LENS				1	
12	98502-04012	.SCREW, PAN HEAD				1	
13	97702-40630	.SCREW, TAPPING				1	
14	306-83311-40	.BULB, FLASHER (12V-21W)				1	
15	95307-12700	NUT				1	
16	10V-83365-00	CAP				1	
17	95307-12700	NUT				1	
18	10V-83365-00	CAP				1	

FIG. 42 METER

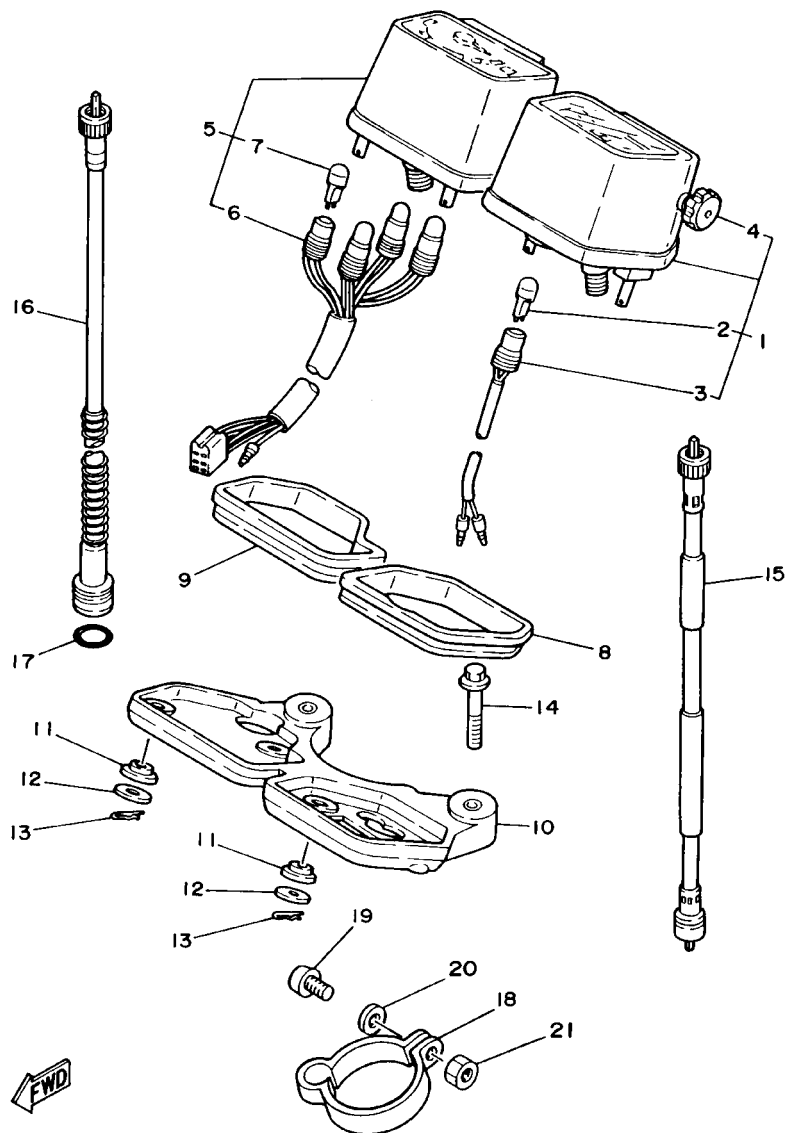

FWD
3NVK100-6420

REF. NO.	PART NO.	DESCRIPTION	3NVY	5LJ1	5LJ2	4FC9	REMARKS
1	55V-83570-10	SPEEDOMETER ASSY	1	1			
	55V-83570-00	SPEEDOMETER ASSY			1	1	
2	4R0-83517-00	.BULB (12V-3.4W T10)	1	1	1	1	
3	5Y1-83536-00	.SOCKET, METER	1	1	1	1	
4	5Y1-83578-00	.KNOB, TRIP METER	1	1	1	1	
5	55V-83540-40	TACHOMETER ASSY	1	1	1	1	
6	30X-83520-00	.SOCKET CORD ASSY	1	1	1	1	
7	4R0-83517-00	.BULB (12V-3.4W T10)	1	1	1	1	
8	5Y1-83513-00	DAMPER	1	1	1	1	
9	5Y1-83541-00	DAMPER	1	1	1	1	
10	5Y1-83519-00	BRACKET, METER	1	1	1	1	
11	1M1-83526-00	DAMPER 2	4	4	4	4	
12	90201-05033	WASHER, PLATE	4	4	4	4	
13	437-83525-00	CLIP	4	4	4	4	
14	95807-06040	BOLT, FLANGE	2	2	2	2	
15	48Y-83550-02	SPEEDOMETER CABLE ASSY	1	1	1	1	
16	30X-83560-00	TACHOMETER CABLE ASSY	1	1	1	1	
17	93210-14104	O-RING	1	1	1	1	
18	3Y1-26397-00	BAND	1	1	1	1	
19	98507-05016	SCREW, PAN HEAD	1	1	1	1	
20	92907-05600	WASHER, PLATE	1	1	1	1	
21	95307-05600	NUT	1	1	1	1	

FIG. 43 HEADLIGHT

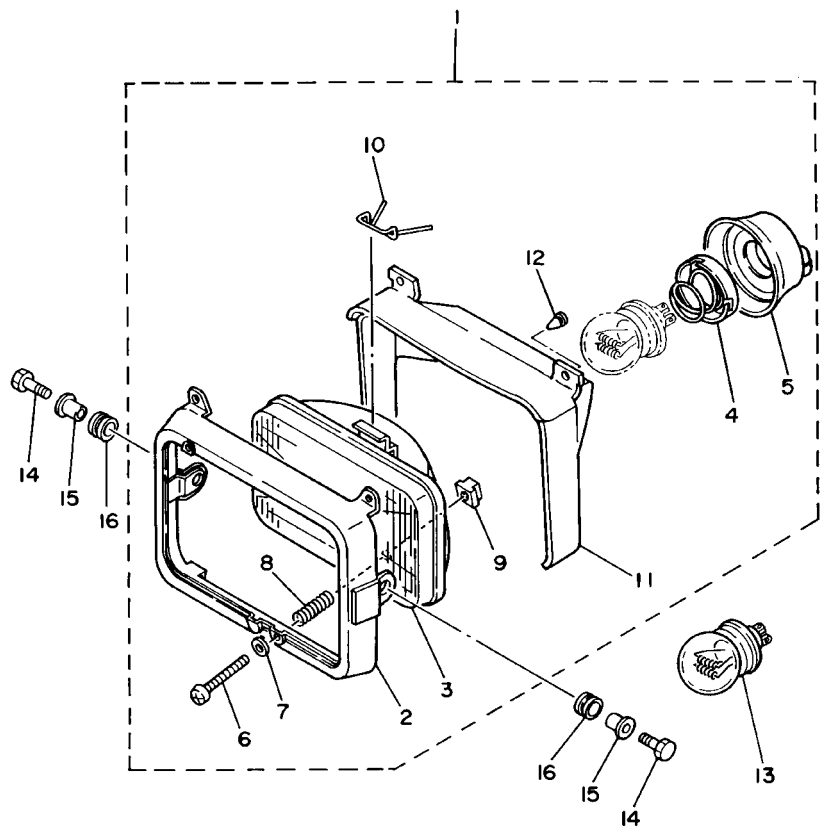

REF. NO.	PART NO.	DESCRIPTION	3NVY	5LJ1	5LJ2	4FC9	REMARKS
1	42U-84303-60	HEADLIGHT UNIT ASSY	1	1	1	1	
2	30X-84115-00	.RIM, HEADLIGHT	1	1	1	1	
3	42U-84321-60	.LENS ASSY	1	1	1	1	
4	341-84312-40	.HOLDER, SOCKET	1	1	1	1	
5	533-84397-40	.COVER, SOCKET	1	1	1	1	
6	10X-84131-00	.SCREW, RIM ADJUSTER	2	2	2	2	
7	233-84127-60	.WASHER, SPECIAL	2	2	2	2	
8	5G2-84332-60	.SPRING, SCREW	2	2	2	2	
9	198-84334-60	.NUT, ADJUSTING	2	2	2	2	
10	5G2-84324-A0	.SPRING, REFLECTOR	1	1	1	1	
11	30X-84196-00	.COVER, SOCKET	1	1	1	1	
12	10V-84198-00	.CLIP, COVER FITTING	2	2	2	2	
13	*	BULB, HEAD LIGHT (12V45/40W)	1	1	1	1	LM
14	97007-06025	BOLT	2	2	2	2	
15	90387-063E6	COLLAR	2	2	2	2	
16	90480-14023	GROMMET	2	2	2	2	



42U110-4350

FIG. 44 TAILLIGHT

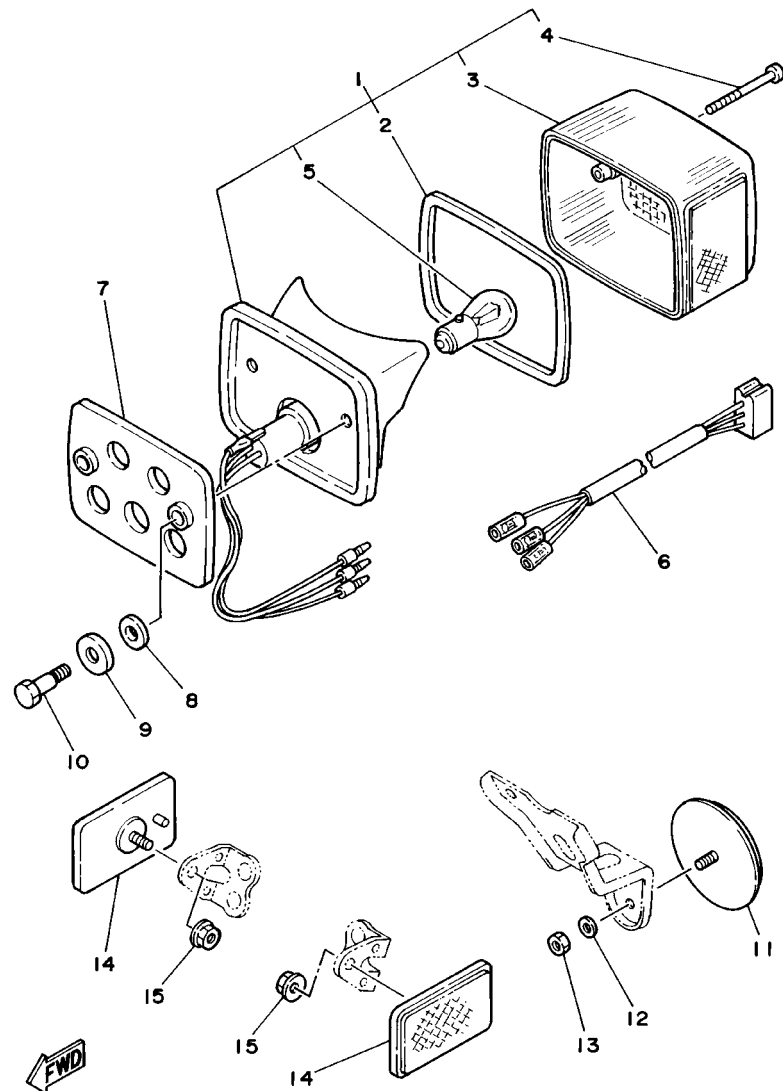

IET171-8380

REF. NO.	PART NO.	DESCRIPTION	3NVY	5LJ1	5LJ2	4FC9	REMARKS
1	1W9-84710-61	TAILLIGHT UNIT ASSY	1	1	1		
2	1M1-84523-60	.GASKET, LENS	1	1	1		
3	1M1-84521-60	.LENS, TAILLIGHT	1	1	1		
4	1M1-84524-60	.SCREW, LENS FITTING	2	2	2		
5	256-84714-61	.BULB (12V-27/8W)	1	1	1		
6	42U-84517-00	CORD, TAILLIGHT	1	1	1		
7	4L0-84753-00	DAMPER	1	1	1		
8	90201-083A0	WASHER, PLATE	2	2	2		
9	90209-08125	WASHER	2	2	2		
10	90109-06005	BOLT	2	2	2		
11	449-85131-02	REFLECTOR, REAR 1	1	1	1		
12	90201-05725	WASHER, PLATE	1	1	1		
13	95307-05600	NUT	1	1	1		
14	20G-85110-00	REFLECTOR ASSY	2	2	2		
15	95707-05500	NUT, FLANGE	2	2	2		

FIG. 45 TAILLIGHT 2

REF. NO.	PART NO.	DESCRIPTION	3NVY	5LJ1	5LJ2	4FC9	REMARKS
1	37E-84710-E1	TAILLIGHT UNIT ASSY				1	
2	1A2-84714-41	.BULB (12V-21/5W)				1	
3	10V-84523-00	.GASKET, LENS				1	
4	37E-84721-E1	.LENS, TAILLIGHT				1	
5	97701-40530	.SCREW, TAPPING				2	
6	10V-84517-00	CORD, TAILLIGHT				1	
7	10V-84527-00	DAMPER				1	
8	90387-07391	COLLAR				2	
9	95707-06500	NUT, FLANGE				2	
10	3Y6-85130-02	REAR REFLECTOR ASSY				1	
11	90201-05036	WASHER, PLATE				1	
12	90201-05725	WASHER, PLATE				1	
13	95307-05600	NUT				1	

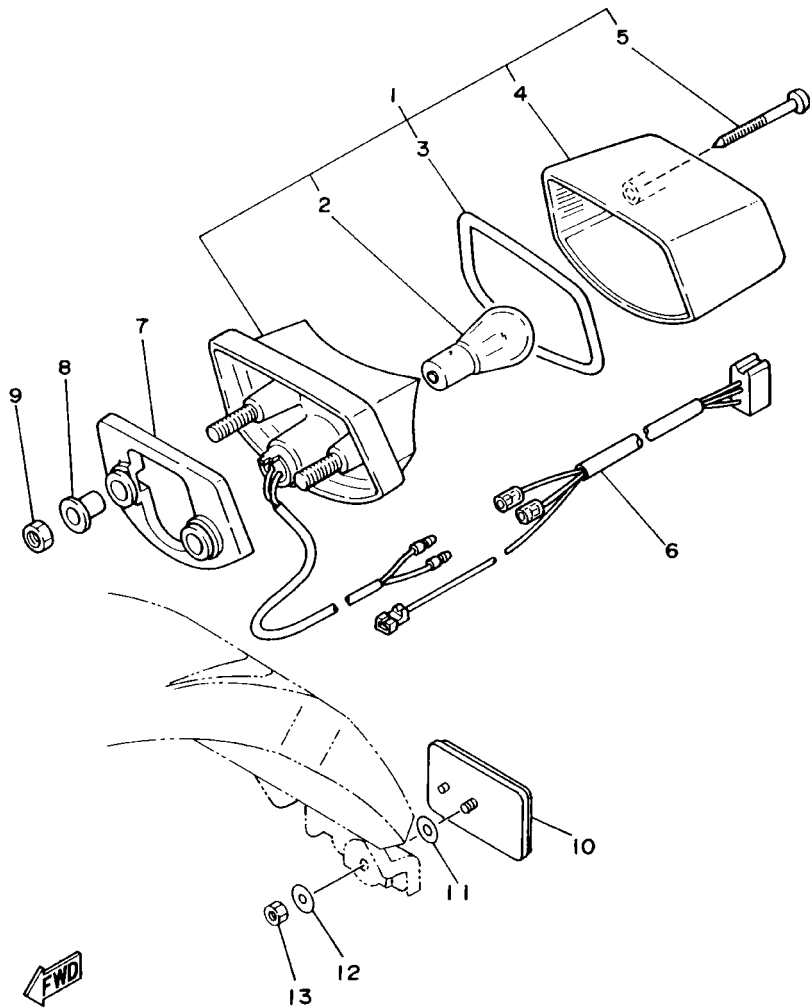

3NVK100-6450

FIG. 46 HANDLE SWITCH. LEVER

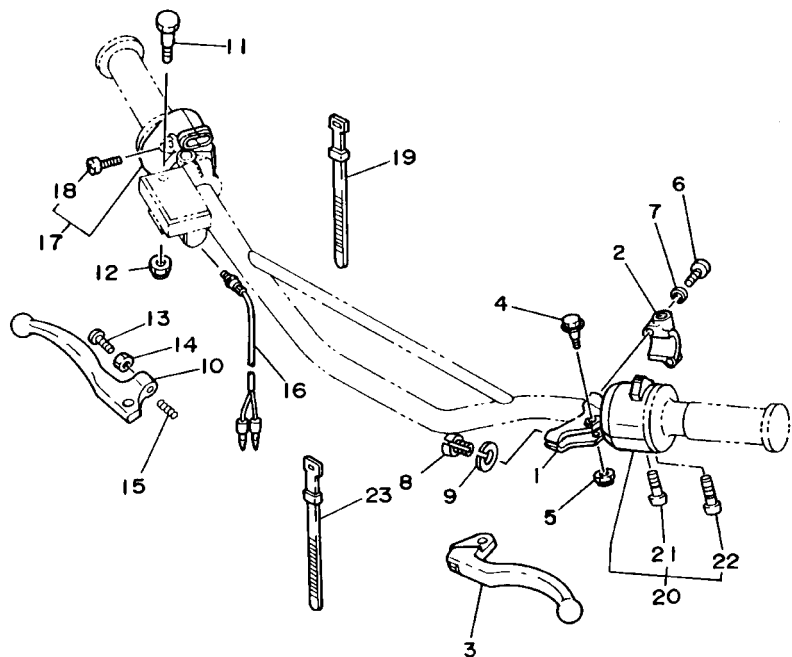

REF. NO.	PART NO.	DESCRIPTION	3NVY	5LJ1	5LJ2	4FC9	REMARKS
1	1LN-82911-00	HOLDER, LEVER 1	1	1	1	1	
2	33G-82913-01	HOLDER, LEVER LOWER 1	1	1	1	1	
3	3FY-83912-01	LEVER 1	1	1	1	1	
4	90109-06799	BOLT	1	1	1	1	
5	95607-06100	NUT, U	1	1	1	1	
6	98507-05020	SCREW, PAN HEAD	2	2	2	2	
7	92907-05100	WASHER, SPRING	2	2	2	2	
8	90123-08046	BOLT	1	1	1	1	
9	90179-08148	NUT	1	1	1	1	
10	3FY-83922-00	LEVER 2	1	1	1	1	
11	90109-06577	BOLT	1	1	1	1	
12	95607-06100	NUT, U	1	1	1	1	
13	90149-06131	SCREW	1	1	1	1	
14	90170-06010	NUT	1	1	1	1	
15	90501-10312	SPRING, COMPRESSION	1	1	1	1	
16	34X-83980-01	FRONT STOP SWITCH ASSY	1	1	1	1	
17	43F-83976-00	SWITCH, HANDLE 1	1	1	1	1	
18	98506-05020	.SCREW, PAN HEAD	2	2	2	2	
19	437-83936-01	BAND, SWITCH CORD	2	2	2	2	
20	21T-83973-01	SWITCH, HANDLE 3	1	1	1	1	
21	90157-05027	.SCREW, PAN HEAD	1	1	1	1	
22	98501-05030	.SCREW, PAN HEAD	1	1	1	1	
23	437-83936-01	BAND, SWITCH CORD	2	2	2	2	



3NVK100-6460

FIG. 47 ELECTRICAL 1

REF. NO.	PART NO.	DESCRIPTION	3NVY	5LJ1	5LJ2	4FC9	REMARKS
1	33G-81960-60	RECTIFIER & REGULATOR ASSY	1	1	1	1	UR STANLEY
	55V-81960-90	RECTIFIER & REGULATOR ASSY	1	1	1	1	UR MATSUSHITA
2	98507-06012	SCREW, PAN HEAD	2	2	2	2	
3	20N-82310-40	IGNITION COIL ASSY	1	1	1	1	
4	98507-06020	SCREW, PAN HEAD	2	2	2	2	
5	371-82370-00	PLUG CAP ASSY	1	1	1	1	
6	30W-82110-01	BATTERY ASSY (GM3-3B)	1	1	1	1	
7	90445-08336	HOSE	1	1	1	1	
8	34M-82131-00	BAND, BATTERY	1	1	1	1	
9	1M1-82115-00	WIRE, PLUS LEAD	1	1	1	1	
10	558-82116-00	WIRE, MINUS LEAD	1	1	1	1	
11	2GK-82501-01	MAIN SWITCH STEERING LOCK	1	1	1	1	
12	90149-06228	SCREW	2	2	2	2	
13	92907-06600	WASHER, PLATE	2	2	2	2	
14	30X-82530-02	STOP SWITCH ASSY	1	1	1	1	
15	4KM-82540-00	NEUTRAL SWITCH ASSY	1	1	1	1	
16	12R-82591-00	BAND	1	1	1	1	
17	2GK-82590-00	WIRE HARNESS ASSY	1	1	1		
	4FC-82590-00	WIRE HARNESS ASSY				1	
18	57T-81325-00	.CONDENSER 1	1	1	1	1	
19	437-83936-01	BAND, SWITCH CORD	4	4	4	4	
20	25G-83936-01	BAND, SWITCH CORD	1	1	1	1	
21	5Y1-82566-00	SWITCH, SIDE STAND	1	1	1		
	3LD-82566-60	SWITCH, SIDE STAND				1	
22	90152-05021	SCREW, COUNTERSUNK	2	2	2		
	98507-05014	SCREW, PAN HEAD				2	
23	4Y3-85590-M0	CONTROL UNIT ASSY	1	1	1	1	

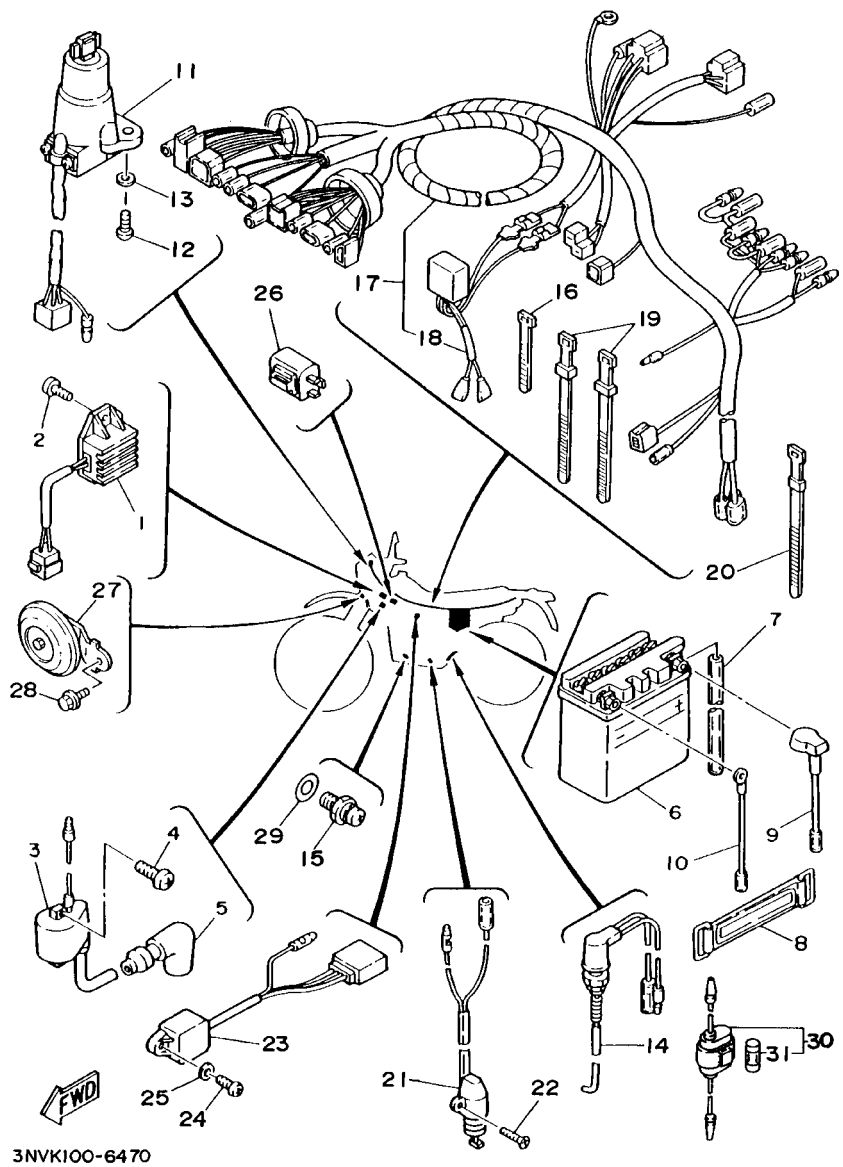
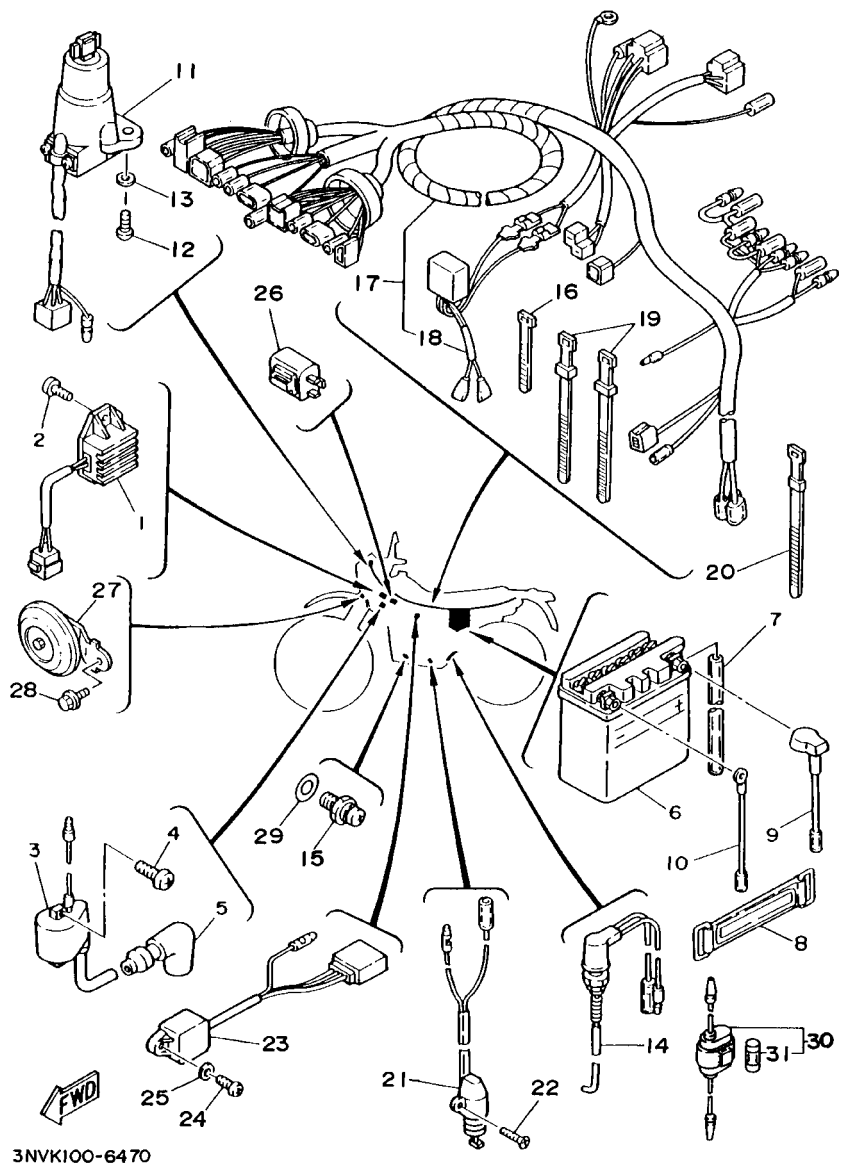

FIG. 47 ELECTRICAL 1



3NVK100-6470

REF. NO.	PART NO.	DESCRIPTION	3NVY	5LJ1	5LJ2	4FC9	REMARKS
24	98507-06016	SCREW, PAN HEAD	1	1	1	1	
25	92907-06600	WASHER, PLATE	1	1	1	1	
26	30X-83350-20	FLASHER RELAY ASSY	1	1	1		
	34L-83350-20	FLASHER RELAY ASSY				1	
27	30X-83371-20	HORN	1	1	1		
	55V-83371-00	HORN				1	
28	95807-06010	BOLT, FLANGE	1	1	1		
	95027-08012	BOLT, FLANGE				1	
29	90430-10148	GASKET	1	1	1	1	
30	116-82150-01	FUSE HOLDER ASSY	1	1	1	1	
31	116-82151-00	.FUSE (10A)	1	1	1	1	

NUMERICAL INDEX

PART NO.	GRID NO.	PART NO.	GRID NO.	PART NO.	GRID NO.	PART NO.	GRID NO.	PART NO.	GRID NO.	PART NO.	GRID NO.
56A-W0041-00	E - 10	30X-12117-00	B - 7	5H0-13440-00	B - 10	56R-14312-35	B - 12	5Y1-14572-00	B - 12	214-15674-00	C - 7
38W-W0045-02	E - 6	30X-12118-00	B - 7	3DC-13447-00	B - 10	14T-14323-00	B - 13		B - 15	214-15686-00	C - 7
34X-W0047-00	E - 6	51Y-12119-00	B - 7	1HX-13575-00	B - 11		C - 2	57R-14611-00	C - 4	30X-16111-00	C - 9
51L-W0048-00	E - 6	30X-12121-00	B - 7	55V-13586-01	B - 11	30X-14340-01	B - 13	4BR-14613-00	C - 4	55V-16150-00	C - 9
34X-W0057-00	E - 6	26H-12153-00-J0	B - 7	42U-13596-01	B - 11		C - 2	55V-14628-00	C - 4	30X-16154-00	C - 9
30X-W2164-00	D - 5	26H-12153-00-Y0	B - 7	3WP-14103-00	B - 13	51Y-14341-00	B - 12	2GK-14711-01	C - 4	3J2-16324-00	C - 9
3LS-W2536-00	E - 7	26H-12168-A0	B - 7	30X-14103-00	C - 2		B - 15	55V-14711-02	C - 4	168-16325-00	C - 9
30X-Y2410-G0-01	D - 15	26H-12168-F0	B - 7	30X-14105-00	B - 15	30X-14342-21	B - 12	4EL-14714-00	C - 4	5Y1-16331-01	C - 9
43E-Y2410-10-01	D - 15	26H-12168-H0	B - 7	1JK-14107-01	B - 12		B - 15	30X-14715-00	C - 4	5Y1-16351-00	C - 9
30X-Y2835-60	E - 13	26H-12168-K0	B - 7		B - 15	288-14343-60	B - 15	55V-14728-00	C - 4	55V-16356-00	C - 9
55V-11101-01	B - 2	26H-12168-M0	B - 7	5H0-14126-00	B - 14	288-14343-63	B - 12	42U-14752-00	C - 4	30X-16357-00	C - 10
2GH-1111G-00	B - 2	26H-12168-R0	B - 7		C - 3	30X-14343-51	C - 2	4BD-14766-00	C - 4	1W1-16358-01	C - 9
30X-11127-00	B - 4	26H-12168-U0	B - 7	30X-14131-00	B - 12	30X-14343-53	B - 13	5Y1-1490A-00	B - 13	55V-16371-00	C - 9
30X-11133-10	B - 2	26H-12168-W0	B - 7		B - 15	5Y1-14349-00	B - 13		C - 2	55V-16380-00	C - 9
34K-11145-00	B - 6	26H-12168-Y0	B - 7	5Y1-14137-00	B - 14		C - 2	1EU-1490J-00	C - 2	51Y-17121-00	C - 11
30X-11161-00	B - 2	26H-12168-00	B - 7	42U-14146-00	B - 14	30X-14355-00	B - 13	51Y-1490J-10	B - 15	55V-17131-00	C - 11
3Y1-11162-00	B - 4	26H-12168-20	B - 7		C - 3		C - 2	56R-1490J-00	B - 13	55V-17151-02	C - 11
30X-11166-00	C - 5	26H-12168-40	B - 7	5Y1-14146-00	B - 13	5Y1-14356-00	B - 12	56R-1490J-10	B - 12	55V-17161-00	C - 11
56R-11166-00	C - 5	26H-12168-60	B - 7		C - 2		B - 15	57T-1490J-00	B - 13	51Y-17211-00	C - 11
55V-11181-00	B - 2	26H-12168-80	B - 7	30X-14148-00	B - 14	5Y1-14357-00	B - 12	57T-1490J-10	B - 12	51Y-17221-00	C - 11
30X-11191-01	B - 2	26H-12169-E0	B - 8		C - 2		B - 15	30X-1490K-00	B - 13	55V-17231-00	C - 11
30X-11192-01	B - 2	26H-12169-G0	B - 8	30X-14149-00	B - 14	30X-14358-00	B - 13		C - 2	55V-17241-00	C - 11
30X-11193-01	B - 2	26H-12169-J0	B - 8		C - 2		C - 2	1LN-14930-00	B - 12	55V-17251-00	C - 11
214-11198-01	C - 5	26H-12169-L0	B - 8	5Y1-14159-00	B - 14	5Y1-14358-00	B - 13		B - 15	55V-17261-01	C - 11
55V-11310-03	B - 4	26H-12169-N0	B - 8		C - 2		B - 15	5H0-14991-00	B - 14	55V-17402-00	C - 11
4DR-11351-00	B - 4	26H-12169-T0	B - 8	7KF-14162-00	B - 13	15A-14371-01	B - 13		C - 2	51Y-17411-00	C - 11
55V-11400-02	B - 5	26H-12169-10	B - 7		C - 2	51Y-14371-01	B - 15	55V-15100-03	C - 5	3Y1-17456-00	C - 12
55V-11412-00	B - 5	26H-12169-30	B - 7	56R-14193-00	B - 14	30X-14384-00	B - 12	30X-15351-00	B - 10	55V-17460-00	C - 11
55V-11422-01	B - 5	26H-12169-50	B - 7	56R-14196-00	B - 14		B - 15	3Y1-15361-00	C - 6	30X-17831-00	C - 13
55V-11454-00	B - 6	26H-12169-70	B - 8	34K-14197-00	B - 13	5Y1-14385-00	B - 12	3Y1-15363-00	C - 6	30X-17841-01	C - 13
30X-11496-00	B - 5	26H-12169-90	B - 8		C - 2		B - 15	30X-15378-00	C - 6	30X-17861-00	C - 13
51Y-11531-00	B - 5	48Y-12171-00	B - 9	42U-14197-00	B - 14	689-14386-00	B - 12	30X-15383-00	C - 5	30X-18101-01	C - 15
51Y-11536-00	B - 6	30X-12176-00	B - 9	56R-14197-00	B - 14		B - 15	3DC-15411-00	C - 6	30X-18110-01	C - 15
30X-11549-00	B - 5	48Y-12181-00	B - 9	30X-14198-00	B - 12	5Y1-14396-00	B - 13	3GJ-15421-00	C - 6	1W6-18113-00	C - 15
30X-11565-00	B - 5	30X-12210-00	B - 9		B - 15		C - 2	30X-15441-00	C - 5	3Y1-18122-00	C - 14
55V-11610-00	B - 5	4FM-12213-00	B - 9	30X-14203-00	B - 12	56R-14396-00	B - 13	4EL-15451-00	C - 6	3Y1-18140-00	C - 15
55V-11610-20	B - 5	30X-12241-00	B - 9		B - 15	30X-14401-00	B - 11	4EL-15461-02	C - 6	30X-18141-00	C - 14
55V-11610-40	B - 6	30X-12251-00	B - 9	30X-14216-00	B - 13	30X-14412-00	B - 11	30X-1561A-00	C - 8	2K7-18151-00	C - 14
55V-11631-01-Y0	B - 5	30X-12252-01	B - 9		C - 2	30X-14426-00	B - 11	30X-1561G-00	C - 8	30X-18161-00	C - 14
55V-11633-00	B - 6	30X-12283-00	B - 2	7KF-14227-00	B - 14	30X-14437-00	B - 11	30X-15620-01	C - 7	30X-18185-00	C - 14
55V-11636-01	B - 5	30X-12288-00	B - 2		C - 3	55V-14437-00	B - 11	30X-15621-01	C - 7	30X-18511-00	C - 14
55V-11638-01	B - 5	30X-12292-00	B - 3	30X-14286-00	B - 13	30X-14451-00	B - 11	30X-15641-01	C - 7	30X-18512-00	C - 14
51Y-11651-01	B - 5	55V-13161-01	B - 10		C - 2	2GV-14452-00	B - 11	30X-15651-01	C - 7	30X-18540-00	C - 14
51Y-11681-00	B - 5	30X-13300-00	B - 10	55V-14301-05	B - 15	30X-14453-01	B - 11	30X-15660-01	C - 7	4DN-18531-00	C - 14
30X-12111-01	B - 7	3Y6-13326-01	B - 10	56R-14301-04	B - 12	30X-14454-01	B - 11	2K7-15668-00	C - 7	4DN-18535-00	C - 14
30X-12113-00	B - 7	30X-13341-00	B - 10	57T-14301-04	B - 12	30X-14458-00	B - 11	55V-15668-00	C - 5	30X-18540-00	C - 14
30X-12114-00	B - 7	51Y-13411-00	B - 10	30X-14312-35	B - 12	5Y1-14536-00	B - 13		C - 7	136-18542-00	C - 14
26H-12116-00	B - 7	3Y1-13416-01	B - 10		B - 15		C - 2	3Y1-15671-00	C - 7	30X-18561-02	C - 14

NUMERICAL INDEX

PART NO.	GRID NO.	PART NO.	GRID NO.	PART NO.	GRID NO.	PART NO.	GRID NO.	PART NO.	GRID NO.	PART NO.	GRID NO.
3YT-21110-00-35	D - 2	30X-22153-00	D - 9	55V-23340-00	D - 14	4Y0-25304-00	E - 7	55V-27311-02	E - 11	5Y1-83313-00	F - 2
56R-21110-00-35	D - 2	30X-2217A-00	D - 8	1W1-23416-00	D - 11	3Y1-25311-00-98	E - 7	42U-27315-01	E - 11	37A-83330-21	F - 2
57T-21110-00-35	D - 2	30X-2217F-01	D - 9		D - 12	146-25315-00	E - 7	30X-27410-00-90	E - 11	5Y1-83330-70	E - 15
3MX-2118K-A0	D - 15	30X-22178-00	D - 2	30X-23435-00-35	D - 11	538-25351-01	E - 7	22W-27411-01-90	E - 11	30X-83350-20	F - 9
5H0-21308-01	D - 3	10V-22184-00	D - 2		D - 12	3R6-25355-01	E - 7	55V-27420-00-90	E - 12	34L-83350-20	F - 9
30X-21315-00	D - 2	3YT-22210-11-33	D - 10	1E6-23441-10-35	D - 11	3Y1-25364-00	E - 7	22W-27421-01-90	E - 12	10V-83365-00	E - 15
30X-21316-00-35	D - 2	3YT-22210-21-33	D - 10		D - 12	3Y1-25366-00-98	E - 7	120-27431-00	E - 12		F - 2
55V-2137W-50	D - 3	3YT-22210-30-33	D - 10	30X-23445-00	D - 11	3Y1-25377-00	E - 7	26F-27432-00-33	E - 12	10V-83368-00	E - 15
55V-2137X-50	D - 3	30X-22216-00	D - 10		D - 12	3Y1-25383-00	E - 8	120-27433-00	E - 12	10V-83369-00	E - 15
30X-2139X-00	D - 3	30X-22226-00	D - 10	134-23484-10	D - 12	3Y1-25388-01	E - 8	55V-27442-00-33	E - 12	30X-83371-20	F - 9
30X-21471-01	D - 2	38M-22311-00	D - 9	56R-24170-00	D - 15	3Y1-25389-00	E - 8	48Y-28100-00	D - 6	55V-83371-00	F - 9
2K7-2148A-00	D - 2	30X-22312-01	D - 9	20K-24180-00	E - 2	55V-25452-50	E - 7		D - 7	5Y1-83513-00	F - 3
30X-21511-30	D - 4	55V-23102-A1	D - 13	22W-24181-00	D - 6	55V-25455-50	E - 7	4K5-2814E-10	B - 11	4R0-83517-00	F - 3
	D - 5	55V-23103-A1	D - 13		D - 7	55V-25715-20	E - 6	55V-28173-01	D - 7	5Y1-83519-00	F - 3
3WF-2153E-70	D - 4	30X-23110-00	D - 13	4L0-24181-00	D - 15	59Y-2580T-10	E - 6	55V-28185-00	D - 7	30X-83520-00	F - 3
	D - 5	53Y-23111-00	D - 13	30X-24182-01	D - 15	48Y-25831-00	E - 6	4U7-28186-00	B - 11	437-83525-00	F - 3
3HP-21568-00	D - 5		D - 14	30X-24183-01	D - 15	34X-25845-00	E - 6	3JJ-28446-A0	E - 3	1M1-83526-00	F - 3
30X-21611-30	D - 5	1W1-23114-L0	D - 13	30X-24186-01	D - 15	4L3-25852-00	E - 10	57T-81325-00	F - 8	5Y1-83536-00	F - 3
42U-21611-10	D - 4		D - 14	30X-24187-00	D - 15	4L0-25854-00	E - 10	33G-81960-60	F - 8	55V-83540-40	F - 3
30X-21621-00	B - 11	4V5-23118-L1	D - 13	3NV-24240-70	D - 15	4L0-25867-00	E - 10	55V-81960-90	F - 8	5Y1-83541-00	F - 3
30X-21629-00	D - 4		D - 14	56R-24314-00	E - 2	39F-24317-00	E - 10	30W-82110-01	F - 8	48Y-83550-02	F - 3
	D - 5	30X-23125-00	D - 13	43E-24315-00	E - 2	48Y-25872-03	E - 10	1M1-82115-00	F - 8	30X-83560-00	F - 3
21T-2163A-00	D - 4	48Y-23126-01	D - 13	23F-24500-01	D - 15	34X-25876-00	E - 10	558-82116-00	F - 8	55V-83570-00	F - 3
42U-21639-00	D - 4	48Y-23136-01	D - 13	360-24512-00	B - 12	34X-25919-00	E - 6	116-82131-00	D - 6	55V-83570-10	F - 3
30X-21641-01	D - 5	30X-23141-00	D - 13		B - 15	2GV-25926-00	E - 6	34M-82131-00	F - 8	5Y1-83578-00	F - 3
42U-21641-00	D - 4		D - 14	4X8-24512-00	D - 15	34X-25937-00	E - 6	116-82150-01	F - 9	3FY-83912-01	F - 7
21T-21685-20	D - 4	48Y-23144-00	D - 13	3AJ-24523-00	D - 15	5R2-25937-00	E - 6	116-82151-00	F - 9	3FY-83922-00	F - 7
42U-21685-00	D - 4	48Y-23145-00	D - 13	3AJ-24534-00	D - 15	1EU-26111-20	E - 9	20N-82310-40	F - 8	25G-83936-01	F - 8
42U-21688-00	D - 4	4FY-23149-00	D - 13	48Y-24602-00	D - 15	55V-2622F-00	E - 9	371-82370-00	F - 8	437-83936-01	B - 14
42U-21689-00	D - 4		D - 14	56R-24602-00	D - 15	55V-26241-00	E - 9	2GK-82501-01	F - 8		B - 3
30X-21711-30-OX	D - 6	5K5-23149-00	D - 13	30X-24734-70	E - 3	55V-26242-00	E - 9	30X-82530-02	F - 8		F - 7
	D - 7	2X1-23151-00	D - 13	30X-24768-00	D - 2	1RF-26243-00	E - 9	4KM-82540-00	F - 8		F - 8
30X-21721-30-OX	D - 6		D - 14	30X-2477A-70	E - 3	55V-26246-00	E - 9	3LD-82566-60	F - 8	21T-83973-01	F - 7
	D - 7	4A1-23156-00	D - 13		E - 4	3Y1-26249-00	E - 9	5Y1-82566-00	F - 8	43F-83976-00	F - 7
3NV-2173E-70	D - 6	509-23158-L0	D - 13	30X-24770-70	E - 3	1Y1-26290-50	E - 9	2GK-82590-00	F - 8	34X-83980-01	F - 7
	D - 7		D - 14		E - 4	1Y1-26290-60	E - 9	4FC-82590-00	F - 8	30X-84115-00	F - 4
3NV-2173F-70	D - 6	55V-23170-00	D - 13	55V-24830-20	E - 4	3Y1-26290-00	E - 9	12R-82591-00	F - 8	233-84127-60	F - 4
	D - 7	3R6-23173-L0	D - 13	30X-24833-00	E - 3	3Y1-26290-10	E - 9	5A8-82591-00	E - 9	10X-84131-00	F - 4
3NV-2179R-B0	D - 6		D - 14	38M-24850-00	E - 3	30X-26302-01	E - 9	1LN-82911-00	F - 7	30X-84196-00	F - 4
3NV-2179V-B0	D - 6	30X-23174-00	D - 11	3MX-24875-A0	D - 4	30X-26335-01	E - 9	33G-82913-01	F - 7	10V-84198-00	F - 4
55V-22110-00-PO	D - 8		D - 12	3TB-24877-A0	E - 3	1E6-26342-00	E - 9	5Y1-83310-70	E - 15	42U-84303-60	F - 4
30X-22123-00	D - 8	278-23181-50	D - 13	3Y1-25026-00-98	E - 7	1E6-26372-00	E - 9	5Y3-83310-21	F - 2	341-84312-40	F - 4
156-22127-00	D - 8		D - 14	48Y-25104-00	E - 5	1T5-26372-00	E - 9	256-83311-70	E - 15	42U-84321-60	F - 4
30X-22128-00	D - 8	3YT-23191-30	D - 14	34X-25111-02-98	E - 5	3Y1-26397-00	F - 3	306-83311-40	F - 2	5G2-84324-A0	F - 4
322-22128-01	D - 8	48Y-23192-00	D - 14	322-25118-00	E - 5	55V-27211-00	E - 11	5Y1-83312-00	E - 15	5G2-84332-60	F - 4
30X-22129-00	D - 10	1W4-23194-L0	D - 14	30X-25181-00	E - 5	30X-27231-00	E - 11		F - 2	198-84334-60	F - 4
30X-22141-00	D - 8	34X-23317-00	D - 11	4KM-25181-00	E - 8	55V-27242-00	E - 11	5Y3-83312-00	F - 2	533-84397-40	F - 4
42U-22151-01	D - 9		D - 12	34X-25190-01	E - 5	1M1-27244-00	E - 11	5Y1-83313-00	E - 15	10V-84517-00	F - 6

NUMERICAL INDEX

PART NO.	GRID NO.	PART NO.	GRID NO.	PART NO.	GRID NO.	PART NO.	GRID NO.	PART NO.	GRID NO.	PART NO.	GRID NO.
42U-84517-00	F - 5	90109-06799	F - 7	90201-05033	F - 3	90209-11262	B - 2	90430-06014	B - 2	90508-26434	C - 15
1M1-84521-60	F - 5	90109-10635	E - 11	90201-05036	F - 6	90209-18208	C - 11	90430-06156	B - 10	90508-32374	C - 15
1M1-84523-60	F - 5	90109-10752	D - 8	90201-05725	F - 5	90209-23241	C - 11	90430-08119	C - 9	90508-324B5	C - 7
10V-84523-00	F - 6		D - 9		F - 6	90209-23242	B - 5	90430-10148	F - 9	90560-12191	C - 15
1M1-84524-60	F - 5	90109-10753	D - 10	90201-06071	D - 2	90209-38266	B - 5	90430-10188	B - 10	90560-15290	E - 5
10V-84527-00	F - 6	90109-121A1	D - 8	90201-06380	D - 4	90215-08160	E - 7	90445-08336	F - 8	90560-17239	C - 7
1W9-84710-61	F - 5	90116-08425	E - 7	90201-06557	E - 3	90215-16156	C - 9	90445-10008	D - 15	90560-17311	E - 7
37E-84710-E1	F - 6	90116-10378	B - 2	90201-06778	D - 4	90215-16221	B - 6	90460-49058	B - 11	91A20-07018	B - 11
1A2-84714-41	F - 6	90119-06063	D - 4		D - 5	90215-16222	C - 9	90462-08062	C - 6	91A21-07020	E - 2
256-84714-61	F - 5		D - 5	90201-083A0	F - 5	90215-16289	C - 9	90464-60067	E - 2	91317-06010	E - 10
37E-84721-E1	F - 6		D - 7	90201-08310	D - 2	90240-06076	E - 11	90465-08277	C - 5	91317-06012	B - 2
4L0-84753-00	F - 5	90123-08046	F - 7	90201-08326	C - 4	90240-07105	B - 5	90467-09006	D - 15	91317-06020	B - 11
20G-85110-00	F - 5	90149-05110	B - 10	90201-08366	D - 2	90240-08084	E - 12		E - 2	91317-06025	B - 9
49R-85112-00	D - 14	90149-06011	D - 15	90201-087G0	B - 4	90249-12008	E - 11	90467-11106	E - 2		C - 4
3Y6-85130-02	F - 6	90149-06131	F - 7	90201-08753	D - 2	90267-40029	D - 5	90467-13042	B - 11		C - 6
449-85131-02	F - 5	90149-06228	F - 8	90201-100E9	D - 10	90269-04003	D - 12	90467-14015	C - 5	91317-06030	C - 6
2GK-85510-21	E - 14	90149-06285	D - 3		D - 8	90280-05013	B - 5	90480-01141	D - 6	91317-06040	C - 6
4FC-85510-00	E - 14	90149-08067	C - 9		D - 9	90282-05034	B - 6		D - 7	91317-06065	B - 10
55V-85512-00	E - 14	90151-06013	C - 14	90201-101A4	B - 2	90282-07057	C - 9	90480-08608	E - 5	91401-20012	E - 11
30X-85513-00	E - 14	90152-05021	F - 8	90201-10118	E - 10	90338-11125	B - 2		E - 8		E - 12
56R-85513-00	E - 14	90157-05027	F - 7	90201-10119	B - 10	90340-14132	C - 5	90480-10068	E - 7	91401-25012	E - 12
30X-85514-00	E - 14	90159-06010	C - 9	90201-105E8	C - 13	90380-22111	D - 8	90480-12053	D - 3	91401-30030	E - 5
56R-85514-00	E - 14	90159-06013	D - 9	90201-10508	B - 5	90384-18157	D - 10		D - 6		E - 7
2GK-85540-20	E - 14	90159-06033	D - 4	90201-10614	C - 8	90386-18115	D - 8		D - 7	91701-06022	E - 11
4FC-85540-00	E - 14	90159-06060	E - 13	90201-120A5	D - 8		D - 9		E - 13	91701-06032	E - 12
3M5-85546-00	E - 14	90159-06181	E - 6	90201-120E6	D - 10	90386-20120	D - 8	90480-14023	F - 4	92017-08016	E - 12
55V-85550-21	E - 14	90164-06017	C - 4	90201-12163	C - 13	90387-063E6	F - 4	90480-15342	D - 15	92901-04100	B - 12
30X-85580-00	E - 14	90170-06010	F - 7	90201-12541	E - 11	90387-063G3	D - 15	90480-16233	D - 2		B - 13
4Y3-85590-M0	F - 8	90170-08258	E - 7	90201-12588	C - 15	90387-066K1	D - 9	90501-07629	B - 5		B - 15
341-92090-60	D - 14	90170-16326	B - 6	90201-14215	D - 8	90387-06681	D - 4	90501-10245	E - 11		C - 2
90101-06278	E - 7		C - 9	90201-153A1	C - 7		D - 5	90501-10312	F - 7		E - 14
90101-06288	E - 11	90170-16343	C - 9	90201-155K6	C - 7		E - 9	90501-12081	C - 7	92901-04600	B - 12
90105-06153	B - 2	90171-14020	E - 5	90201-15701	C - 7	90387-07391	F - 6	90501-16107	C - 7		B - 15
90105-06406	B - 4	90171-16024	E - 8	90201-15785	E - 5	90387-07674	D - 2	90501-18576	B - 10	92901-05100	E - 14
90105-07515	B - 9	90175-06013	E - 11	90201-163H8	E - 5	90387-121J0	D - 10	90501-22721	B - 5	92907-05100	F - 7
90105-08099	D - 2	90176-08026	B - 4	90201-17255	C - 15	90387-121L6	D - 9	90501-23391	C - 9	92907-05600	B - 11
90105-10259	E - 6	90179-06498	E - 9	90201-177G4	C - 11	90387-126J8	D - 8	90506-15260	E - 7		D - 11
90105-10290	B - 5	90179-08148	F - 7		C - 7	90387-12787	C - 15	90506-18154	E - 11		D - 12
90105-10608	B - 2	90179-25033	D - 11	90201-20279	E - 12	90387-140J9	D - 8	90506-18224	E - 12		F - 3
90105-14102	D - 11		D - 12	90201-20685	C - 7	90387-15600	E - 5	90506-26225	E - 11	92907-06100	D - 4
	D - 12	90185-08089	D - 2	90201-207G6	B - 6	90387-17141	E - 8	90506-29276	E - 11	92907-06200	C - 9
90109-06005	F - 5	90185-10037	E - 11	90201-243A2	D - 8	90387-172J0	C - 5	90508-12430	C - 14		E - 11
90109-064F0	B - 2	90185-10120	D - 10	90202-05193	D - 15	90387-17783	C - 5	90508-14352	E - 11	92907-06600	B - 9
90109-06418	B - 2		D - 8	90206-06090	C - 4	90387-227H7	E - 10	90508-14433	C - 9		C - 4
90109-06419	B - 10		D - 9	90208-04029	D - 12	90401-10034	B - 10	90508-14630	C - 8		C - 8
90109-065G4	E - 6	90185-12119	D - 8	90209-06187	D - 3	90401-10159	E - 10	90508-18606	B - 2		D - 15
90109-06577	F - 7	90185-14070	D - 8		D - 9	90413-05008	B - 14	90508-20023	E - 11		D - 2
90109-06584	B - 2	90201-04018	D - 5	90209-08125	F - 5	90430-05126	B - 10		E - 12		D - 3

NUMERICAL INDEX

PART NO.	GRID NO.	PART NO.	GRID NO.	PART NO.	GRID NO.	PART NO.	GRID NO.	PART NO.	GRID NO.	PART NO.	GRID NO.
92907-06600	D - 4	93332-00001	D - 11	95307-05600	F - 5	97027-06020	C - 15	98507-06070	C - 5		
	D - 9		D - 12		F - 6	97701-40530	F - 6	98580-04015	B - 12		
	E - 10	93332-00008	D - 11	95307-06600	C - 9	97702-40530	E - 15		B - 15		
	E - 14		D - 12		D - 4	97702-40630	F - 2	98706-04012	E - 10		
	F - 8	93410-17037	C - 11		E - 7	97801-03008	D - 15	98707-06016	C - 5		
	F - 9	93410-20038	C - 7	95307-06700	E - 11	97801-04010	B - 13	98901-04006	B - 13		
92907-08200	E - 3	93410-22039	C - 11	95307-06800	C - 8		C - 2		C - 2		
92990-04100	B - 12	93410-26067	C - 11	95307-12700	E - 15	97801-04012	B - 13	98907-06010	C - 4		
	B - 15	93420-28055	C - 9		F - 2		C - 2	98907-06012	D - 5		
93101-17093	C - 11	93430-09038	E - 11	95607-06100	D - 4	97801-05010	B - 12	99001-07600	C - 14		
93101-25106	B - 6	93440-10109	B - 2		D - 5		B - 15	99001-10600	C - 7		
93102-08307	C - 13	93450-19095	B - 6		F - 7	98501-04008	B - 13	99009-10400	B - 10		
93102-10207	C - 8	93507-32009	C - 7	95607-08100	D - 3		C - 3		C - 13		
93102-12106	C - 15	93511-32017	C - 10	95707-05500	F - 5		E - 14		C - 14		
93102-12321	B - 3	93602-13177	B - 5	95707-06500	F - 6	98501-04010	B - 14		C - 8		
93102-14209	C - 9	93603-12030	B - 10	95807-06008	C - 4		C - 2	99009-15400	C - 7		
93102-17263	C - 7	93604-08071	C - 14	95807-06010	E - 4	98501-04012	F - 2	99009-17400	C - 15		
93102-20281	E - 5	93604-18100	C - 14		F - 9	98501-04016	B - 12		C - 7		
93102-25226	C - 11	93604-29151	C - 14	95807-06012	B - 11		B - 15	99009-47500	E - 7		
93102-25305	C - 5	93605-10090	B - 5		D - 11	98501-05012	E - 14	99247-00100	E - 13		
93102-28022	E - 7	93608-30152	C - 15		D - 12	98501-05020	E - 14	99510-08016	B - 2		
93106-22019	D - 8	93700-06004	D - 8	95807-06016	E - 3	98501-05030	F - 7	99530-12016	C - 5		
93109-18020	D - 8		D - 9		E - 4	98501-05035	E - 14		C - 6		
	D - 9	93700-06009	D - 8	95807-06040	F - 3	98502-04010	E - 15	99530-14016	B - 4		
93210-06422	C - 9	94111-182G9	E - 8	95807-06050	D - 9	98502-04012	F - 2		C - 5		
93210-07135	B - 10	94130-213G0	E - 5	95807-08016	E - 4	98506-05020	F - 7				
93210-10096	B - 10	94227-21123	E - 5	95807-08050	D - 2	98507-05014	B - 11				
93210-10166	E - 2	94237-18120	E - 8	95817-08014	C - 4		F - 8				
93210-14104	F - 3	94330-21084	E - 5	95817-08020	C - 4	98507-05016	F - 3				
93210-19123	C - 6	94340-18086	E - 8		E - 12	98507-05018	D - 11				
93210-30611	B - 11	94416-21419	E - 5	95817-08060	D - 2		D - 12				
93210-347A1	B - 10	94421-18418	E - 7	95817-08070	D - 2	98507-05020	F - 7				
93210-64297	B - 10	94581-61128	E - 8	95824-08035	D - 11	98507-06010	C - 4				
93210-89447	B - 4	94581-61130	E - 8		D - 12	98507-06012	C - 6				
93306-00315	C - 11	94590-91136	B - 9	97007-06012	D - 15		D - 9				
93306-20205	E - 5	94681-61011	E - 8		D - 9		F - 8				
93306-20310	E - 7	94701-00157	B - 2	97007-06016	D - 3	98507-06016	C - 5				
93306-20332	C - 11	94701-00181	B - 2	97007-06020	D - 2		D - 9				
93306-20427	C - 11	94701-00333	B - 2		D - 4		E - 14				
93306-20446	E - 7	95021-08040	D - 14	97007-06025	D - 15		E - 3				
93306-20532	B - 6	95027-08012	E - 15		E - 10		F - 9				
	C - 11		F - 9		F - 4	98507-06020	F - 8				
93306-30622	B - 5	95027-08040	C - 4	97007-06045	D - 4	98507-06025	B - 10				
93306-30630	B - 5		D - 11	97007-08014	E - 3		C - 13				
93306-90501	C - 14		D - 12	97017-08030	C - 7	98507-06030	C - 5				
93310-738N1	B - 5	95307-05600	D - 11	97027-06010	C - 12		C - 6				
93315-31428	C - 10		D - 12	97027-06016	B - 9	98507-06040	E - 9				
93317-32231	D - 8		F - 3		C - 7	98507-06060	C - 5				

CONTENTS

ENGINE

CYLINDER HEAD	B2
CYLINDER	B4
CRANKSHAFT. PISTON	B5
VALVE	B7
CAMSHAFT. CHAIN	B9
OIL PUMP	B10
INTAKE	B11
CARBURETOR	B12
CARBURETOR 2	B15
EXHAUST	C4
CRANKCASE	C5
CRANKCASE COVER 1	C6
STARTER	C7
CLUTCH	C9
TRANSMISSION	C11
TACHOMETER GEAR	C13
SHIFT CAM. FORK	C14
SHIFT SHAFT	C15

CHASSIS

FRAME	D2
FENDER	D4
FENDER 2	D5
SIDE COVER	D6
SIDE COVER 2	D7
REAR ARM	D8
REAR SUSPENSION	D10
STEERING	D11
STEERING 2	D12
FRONT FORK	D13
FUEL TANK	D15
SEAT	E3

SEAT 2	E4
FRONT WHEEL	E5
FRONT BRAKE CALIPER	E6
REAR WHEEL	E7
STEERING HANDLE. CABLE	E9
FRONT MASTER CYLINDER	E10
STAND. FOOTREST	E11
COWLING 1	E13
GENERATOR	E14
FLASHER LIGHT	E15
FLASHER LIGHT 2	F2
METER	F3
HEADLIGHT	F4
TAILLIGHT	F5
TAILLIGHT 2	F6
HANDLE SWITCH. LEVER	F7
ELECTRICAL 1	F8

INDEX

NUMERICAL INDEX	M1
-----------------------	----